



SANY

Quality Changes the World



SANY CRAWLER CRANE SCC 8300

CRAWLER CRANE

CONTENT

P2

SCC8300 Crawler Crane

Outline Dimensions

Technical Features

Main Performance Parameters

Transport Dimensions

Luffing Jib Operating Condition Transport Trailer Summary

Self-assembly Diagram

P19

Specifications

Superstructure

Undercarriage

Operation Devices

Safety Devices

P25

Operating Condition Combinationns

Operating conditions combination

H operating conditions boom combination

HJ operating conditions

LJ operating conditions

FJ operating conditions

FJ_h operating conditions

HJFJ operating conditions

SCC8300

02 Outline dimensions

04 Technical features

05 Main performance parameters

06 Transport dimensions

12 Luffing jib operating condition transport trailer summary

13 Self-assembly diagram

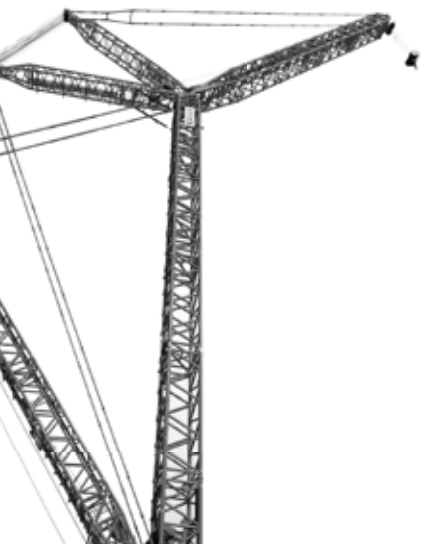

OUTLINE DIMENSIONS

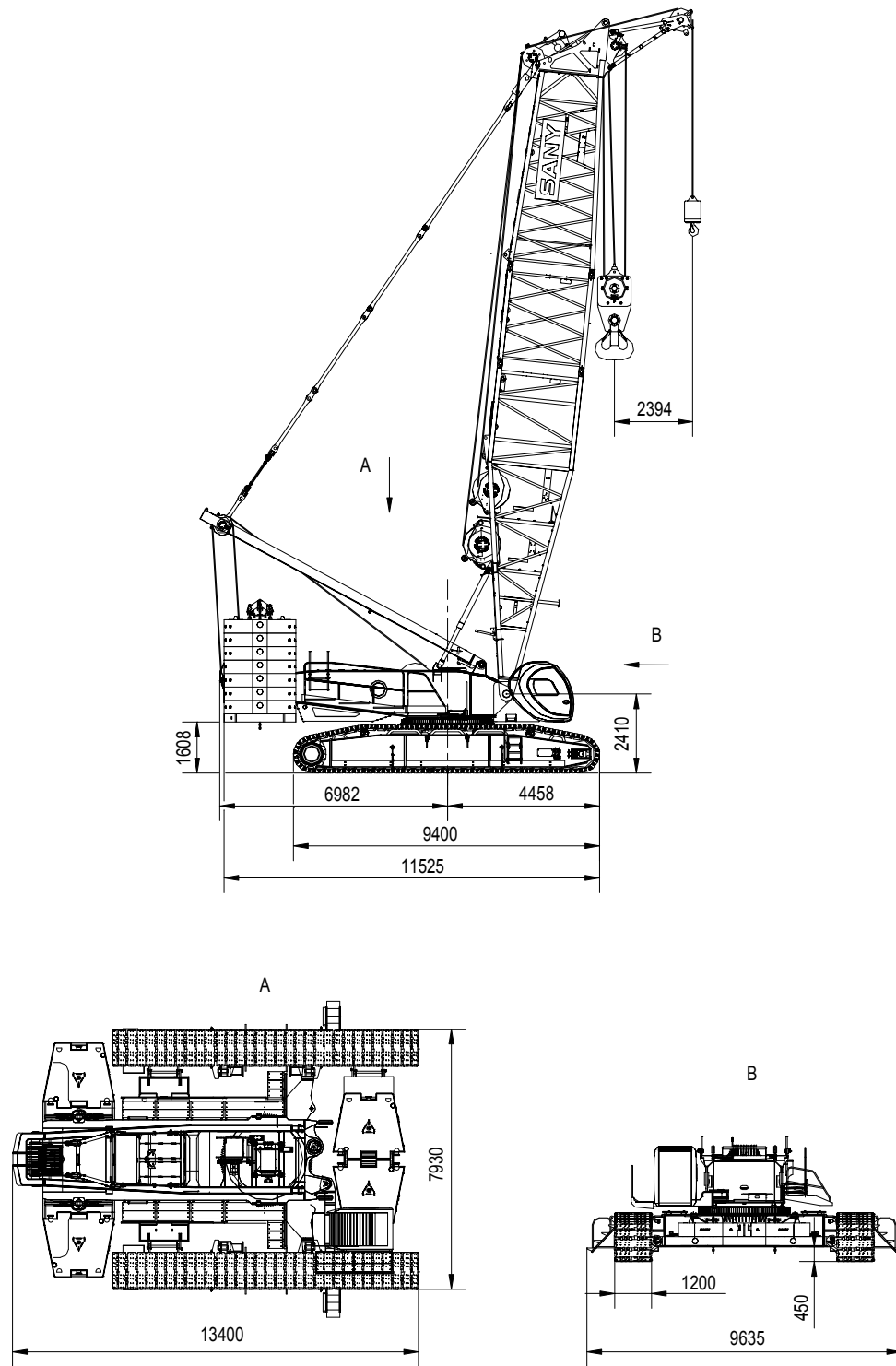

OUTLINE DIMENSIONS

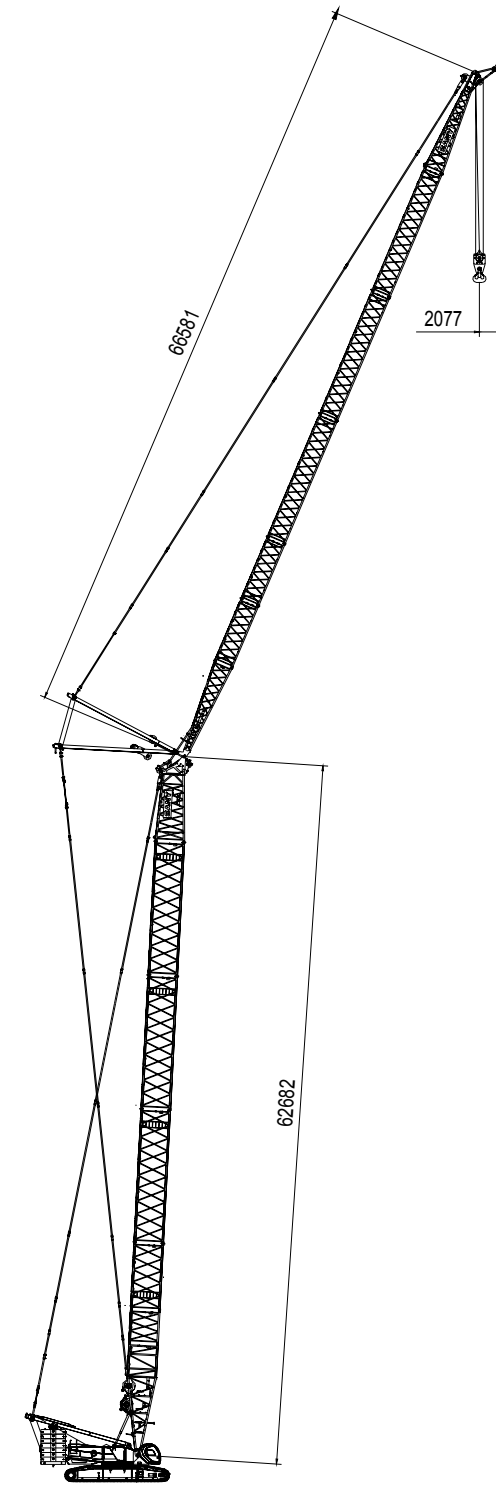

TECHNICAL FEATURES

1. Environment adaptation:

The crane can work in the environment between -30° C and 50° C and can be operated at the altitude less than 2000m as well as in the extreme windy areas(only after installing some optional parts);

2. Mechanism parameters:

With the boom luffing time of 2min, the main hoisting speed of 142m/min, the swing speed of 1.85r / min and the travel speed of 1.3 km/h;

3. Basic machine disassembly:

The winch can be dragged by the clutch for easy reeving, to remotely control the assembly and disassembly of main machine, to support the self assembly and disassembly of the whole machine, with the quick-change rope connectors and winch wire rope head used;

4. Configuration features:

GPS remote monitoring system and vibration handle;

5. Environmental protection standard:

The engine emissions should meet the requirement of Europe and America standard; the noise should comply with the 2000/14/EC about the outdoor equipment noise emission directive and the vibration should meet the requirement of ISO2631- relative standard directive;

6. Maintenance:

It takes approximately no more than 30min/person for routine maintenance;

7. Control system:

There are two operation/installation models. It has the center of gravity of machine and levelness real-time display, machine-leaving stop action, emergency electrical control, lightning protection, and closed-circuit monitoring functions, and is equipped with the electrical and mechanical protective devices;

8. Operating conditions combination:

The boom rated lifting capacity is 300t and the rated lifting moment is 1652Nm. There are seven operating conditions: H operating condition (20m~92m), combined boom operating condition (58m~100m), luffing jib operating condition (62m+66m), fixed jib operating condition (68m+42m), heavy fixed jib operating condition (74m+18m), combined boom + light fixed jib operating condition (88m+37m), and boom + luffing jib + light fixed jib operating condition (62m+60m+37m);

9. Counterweight combination:

The central counterweight can be interchanged with the rear counterweight, having series 1 (without central counterweight) and series 2 (with central counterweight) counterweight program;

10. Man-machine design:

The cab is spacious and bright, with a wide view and with pitching allowed; and the control lever and panels arrangement meets the requirement of man-machine design;

11. Optimization design:

The machine is designed according to the ANSI B30.5 EN13000 and GB3811 standards, with the transport dimension and weight complying with the domestic and international road transport regulations, having the universal design to ensure the Euro III emission upgrade to Euro IV emission;

12. Electrical control system:

The fully electrically controlled system is adopted, with self-diagnostic function, equipped with the electrical backup system;

13. Lubrication system:

The centralized lubrication system automatically controlled is adopted, with automatic lubrication for key moving parts.

14. Optional Configuration:

Main and auxiliary winch free hook and third winch.

MAIN PERFORMANCE PARAMETERS

Main performance parameters of SCC8300 crawler crane			
Performance index	Unit	Parameter	
Max. rated lifting capacity	t	300	
Maximum rated lifting moment	t•m	1652	
Boom operating condition	Max. rated lifting capacity	t	300
	Maximum lifting moment	t•m	1652
	Boom length	m	20~92
	Boom luffing angle	°	30 ~84
	Max. rated lifting capacity	t	111
	Combined boom length	m	58~100
Combined boom operating condition	Combined boom luffing angle	°	30 ~84
	Max. rated lifting capacity	t	138
Boom + luffing jib operating condition	Boom length	m	20~62
	Luffing jib length	m	18~66
	Boom luffing angle	°	65~87
	Luffing jib luffing angle	°	15~77
Boom extension operating condition	Max. rated lifting capacity	t	30t
	Max. rated lifting capacity	t	58t
Boom + Fixed jib operating condition (optional)	Boom length	m	20~68
	Fixed jib length	m	13~42
	Boom luffing angle	°	30~87
	Angle between fixed jib and boom	°	10/20/30
Boom + Fixed jib (heavy) operating condition(optional)	Max. rated lifting capacity	t	87
	Boom length	m	20~74
	Fixed jib length	m	12~18
	Angle between fixed jib and boom	°	10/15/20
Combined boom + Fixed jib (light) operating condition (optional)	Max. rated lifting capacity	t	25
	Boom length	m	64~88
	Fixed jib length	m	13~37
	Boom luffing angle	°	30~87
Boom + Luffing jib + Fixed jib (light) operating condition (optional)	Angle between fixed jib and boom	°	10/20/30
	Max. rated lifting capacity	t	25
	Boom length	m	56~62
	Luffing jib length	m	48~60
	Fixed jib length	m	13~37
	Boom luffing angle	°	75~87
	Luffing jib luffing angle	°	65~77
	Angle between fixed jib and jib	°	10

TRANSPORT DIMENSIONS

Basic Machine	×1
Length (L)	13.23m
Width (W)	3.00m
Height (H)	3.20m
Weight	45t
Track Assembly	×2
Length (L)	9.38m
Width (W)	1.20m
Height (H)	1.49m
Weight	24t
Boom Base (including winch)NO.2825A	×1
Length (L)	10.35m
Width (W)	2.94m
Height (H)	3.14m
Weight	16.9t
3m Boom Insert NO.2825A	×1
Length (L)	3.18m
Width (W)	2.94m
Height (H)	2.84m
Weight	1.35t
6m Boom Insert NO.2825A	×2
Length (L)	6.18m
Width (W)	2.94m
Height (H)	2.84m
Weight	2.24t
12m Boom Insert INO.2825A	×4
Length (L)	12.18m
Width (W)	2.94m
Height (H)	2.84m
Weight	3.93t

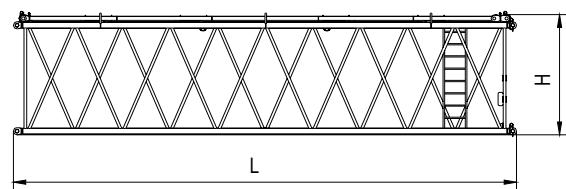
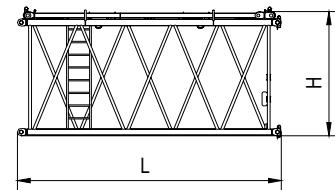
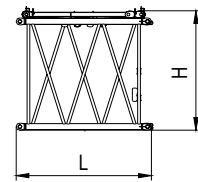
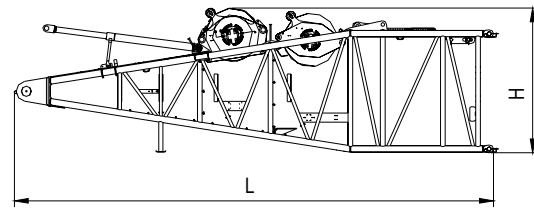
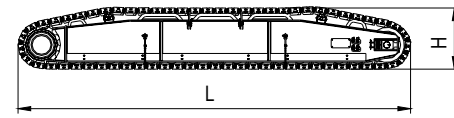
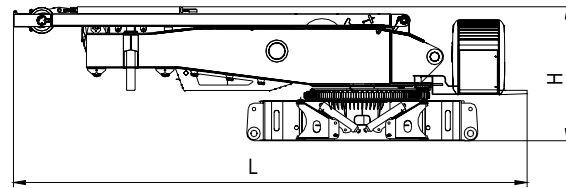

TRANSPORT DIMENSIONS

12m Boom Insert II NO.2825A	×1
Length (L)	12.18m
Width (W)	2.94m
Height (H)	2.84m
Weight	3.43t
Boom Tip NO.2825A	×1
Length (L)	7.98m
Width (W)	2.94m
Height (H)	3.20m
Weight	6.86t
Luffing Jib Tip NO.2316A	×1
Length (L)	9.83m
Width (W)	2.42m
Height (H)	2.07m
Weight	4.44t
Luffing Jib Base and Mast O.2316A	×1
Length (L)	12.41m
Width (W)	2.42m
Height (H)	3.19m
Weight	8.60t
6m Luffing Jib Insert NO.2316A	×2
Length (L)	6.15m
Width (W)	2.42m
Height (H)	1.91m
Weight	1.42t
12m Luffing Jib Insert NO.2316A	×3
Length (L)	12.15m
Width (W)	2.42m
Height (H)	1.91m
Weight	2.48t

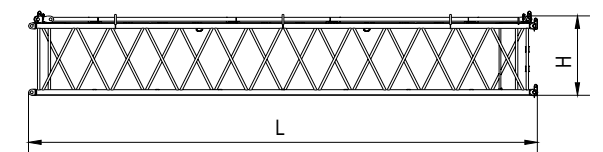
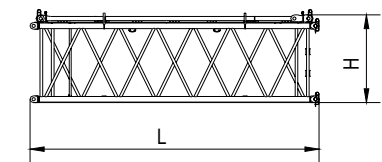
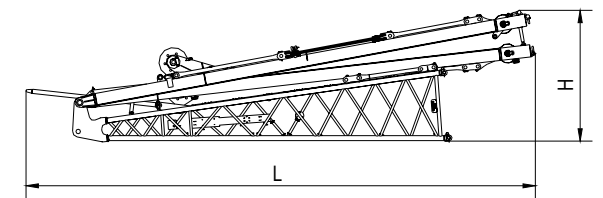
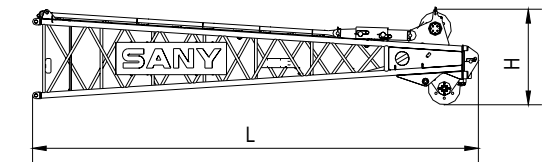
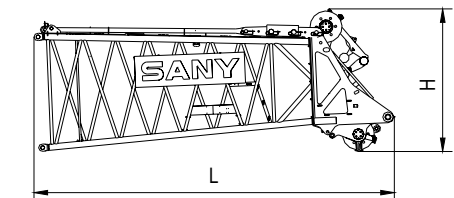
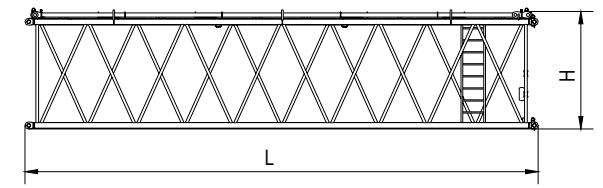

TRANSPORT DIMENSIONS

12m Tapered Insert NO.2825A /NO.2316A	×1
Length (L)	12.19m
Width (W)	2.94m
Height (H)	2.84m
Weight	3.50t
Boom Extension	×1
Length (L)	3.08m
Width (W)	1.08m
Height (H)	1.08m
Weight	0.64t
Jib Extension	×1
Length (L)	2.27m
Width (W)	0.76m
Height (H)	0.77m
Weight	0.42t
Fixed Jib Base NO.1412A	×1
Length (L)	7.91m
Width (W)	1.29m
Height (H)	1.31m
Weight	1.26t
Fixed Jib Tip NO.1412A	×1
Length (L)	7.01m
Width (W)	1.29m
Height (H)	1.42m
Weight	1.41t
6m Fixed Jib Insert NO.1412A	×1
Length (L)	6.11m
Width (W)	1.29m
Height (H)	1.45m
Weight	0.75t
11.5m Fixed Jib Insert NO.1412A	×2
Length (L)	11.61m
Width (W)	1.29m
Height (H)	1.45m
Weight	1.30t

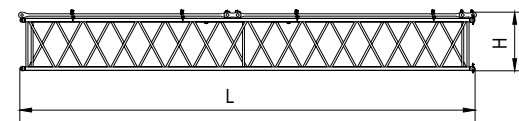
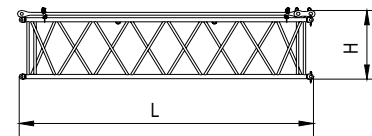
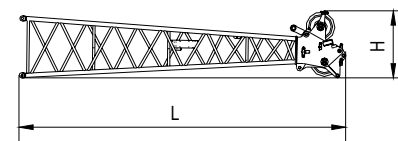
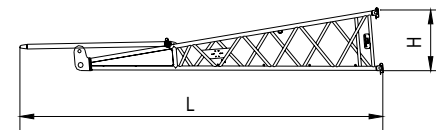
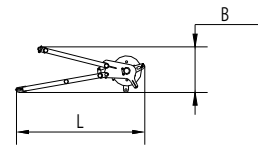
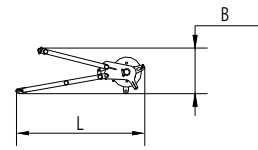
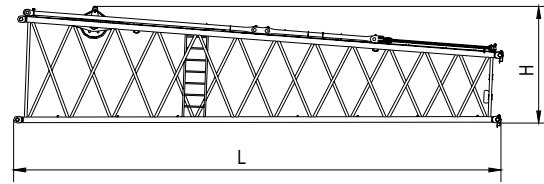

TRANSPORT DIMENSIONS

Light-duty Fixed Jib Base NO.0908A	×1
Length (L)	5.22m
Width (W)	1.01m
Height (H)	0.85m
Weight	0.27t
Light-duty Fixed Jib Tip NO.0908A	×1
Length (L)	5.47m
Width (W)	1.01m
Height (H)	0.84m
Weight	0.47t
3m Light-duty Fixed Jib Insert NO.0908A	×1
Length (L)	3.08m
Width (W)	1.01m
Height (H)	0.85m
Weight	0.12t
6m Light-duty Fixed Jib Insert NO.0908A	×4
Length (L)	6.08m
Width (W)	1.01m
Height (H)	0.97m
Weight	0.60t
Heavy-duty Fixed Jib Base NO.2316A	×1
Length (L)	4.42m
Width (W)	2.42m
Height (H)	1.79m
Weight	1.60t

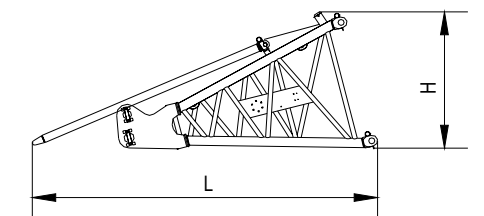
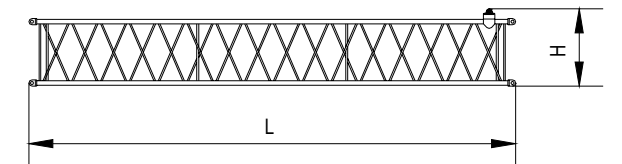
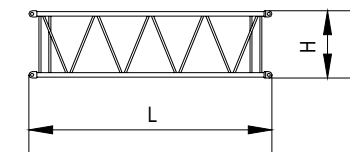
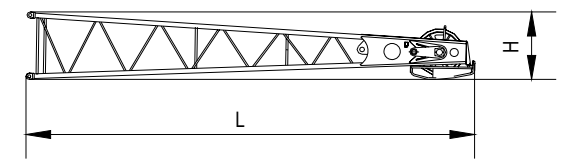
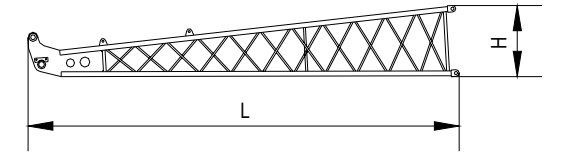

TRANSPORT DIMENSIONS

Rear Counterweight Tray	×1
Length (L)	7.16m
Width (W)	2.20m
Height (H)	0.64m
Weight	16.00t
Central Counterweight Frame	×2
Length (L)	5.48m
Width (W)	1.72m
Height (H)	0.41m
Weight	12.50t
Counterweight(Central Counterweight and Rear Counterweight)	×18
Length (L)	2.00m
Width (W)	2.20m
Height (H)	0.52m
Weight	8t
300t Lifting Hook	×1
Length (L)	2.93m
Width (W)	1.02m
Height (H)	1.39m
Weight	6.20t
150t Lifting Hook	×1
Length (L)	2.55m
Width (W)	1.02m
Height (H)	0.78m
Weight	3.76t

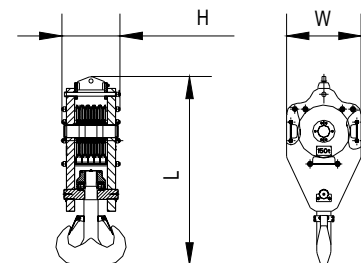
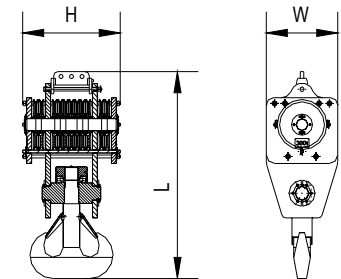
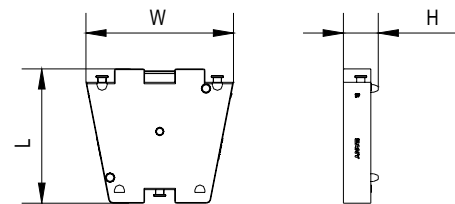
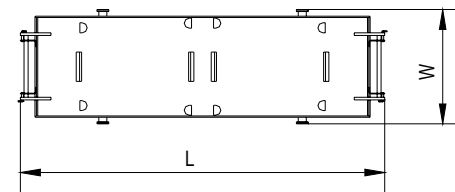
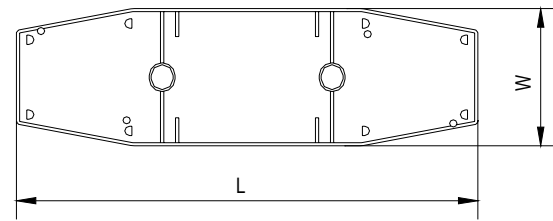

TRANSPORT DIMENSIONS

100t Lifting Hook	×1
Length (L)	2.38m
Width (W)	1.00m
Height (H)	0.70m
Weight	3.21t
50t Lifting Hook	×1
Length (L)	2.20m
Width (W)	1.00m
Height (H)	0.47m
Weight	2.39t
15t Ball Hook	×1
Length (L)	1.30m
Width (W)	0.50m
Height (H)	0.50m
Weight	1.00t
Dolly	×1
Length (L)	2.56m
Width (W)	1.74m
Height (H)	1.00m
Weight	1.00t

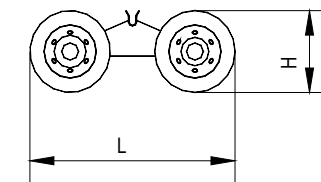
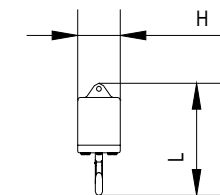
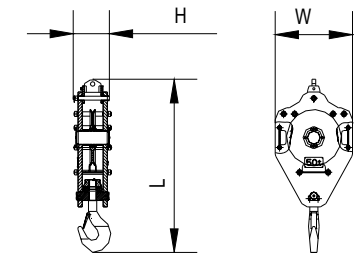
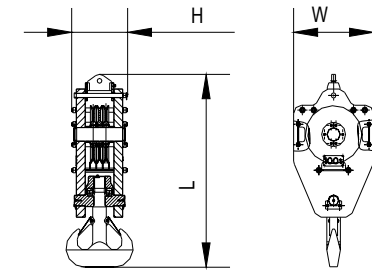

Notes: 1.The transport dimensions of the parts are marked on schematic diagrams, but not draw by scale; the dimensions indicated are the design values excluding package.
2.The weight is the design value and there may be slightly different due to the manufacturing error.

LUFFING JIB OPERATING CONDITION TRANSPORT TRAILER SUMMARY

(62m+66m) Luffing jib operating condition transport trailer summary																	
Name	Weight (t)	1	2	3	4	5	6	7	8	9	10	11	12	13	14	15	16
Main machine	45.00	1															
Track frame	25.00		1	1													
Rear counterweight tray	16.00				1												
Central counterweight frame	12.50					1	1										
Counterweight block	8.00					1	1	2	2	2	2	2	2	2	1	1	
Boom base	16.90																1
3m boom	1.35																1
6m boom	2.24														1		
12m boom	3.93							1	1	1							
Boom tip	6.86														1		
Luffing jib base and mast	8.60															1	
6M luffing jib	1.42			2													
12M luffing jib	2.48										1	1	1				
Luffing jib tip	4.44													1			
Jib extension	0.64																1
150T hook	3.76														1		
100T hook	3.21															1	
50T hook	2.36										1						
15T Ball hook	1.00												1				
Dolly	1.00																1
Weight each trailer (t)		45	25	25	18.8	20.5	20.5	19.9	19.9	19.9	20.8	18.5	19.5	20.4	20.9	19.8	19.9

SELF-ASSEMBLY DIAGRAM

1) Self-assembly of basic machine

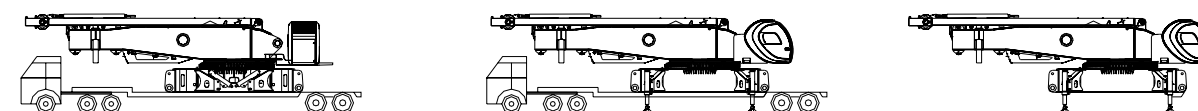

2) Track frame self-assembly

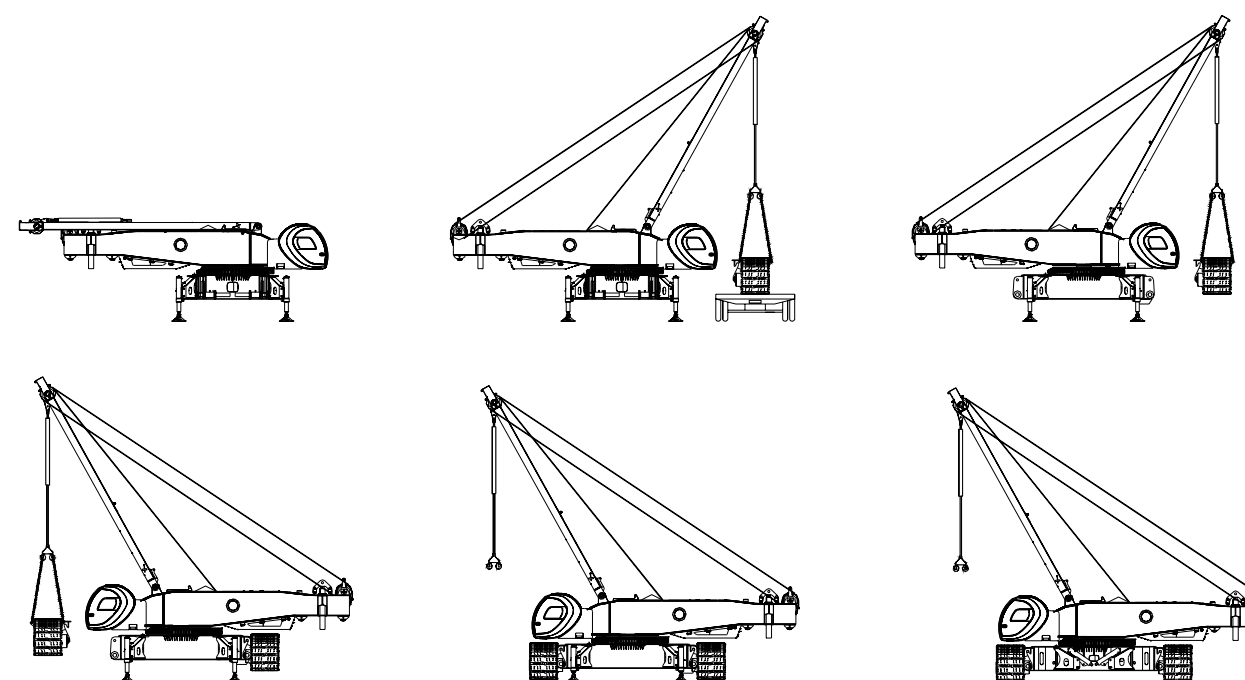

SELF-ASSEMBLY DIAGRAM

3) Counterweight self-assembly

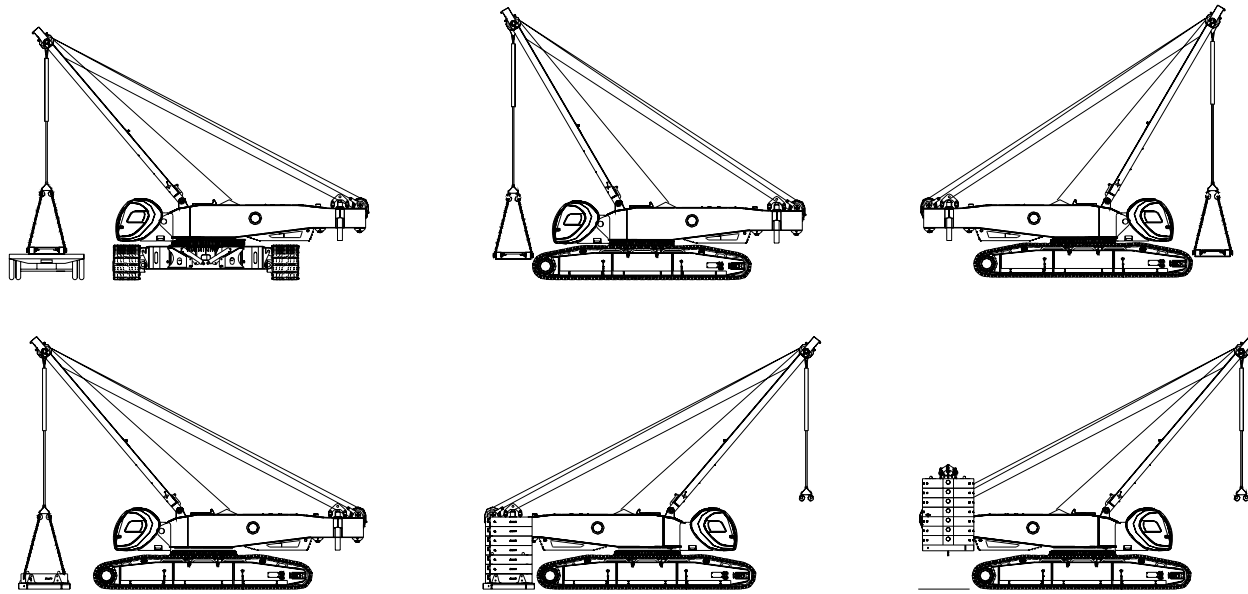

4) Boom base self-assembly

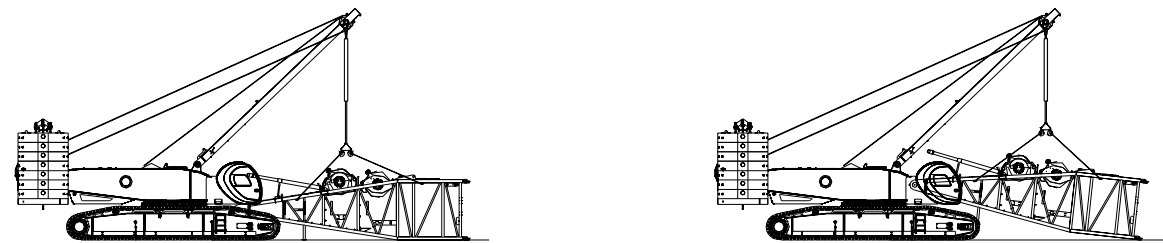

SELF-ASSEMBLY DIAGRAM

1) Installation of basic boom

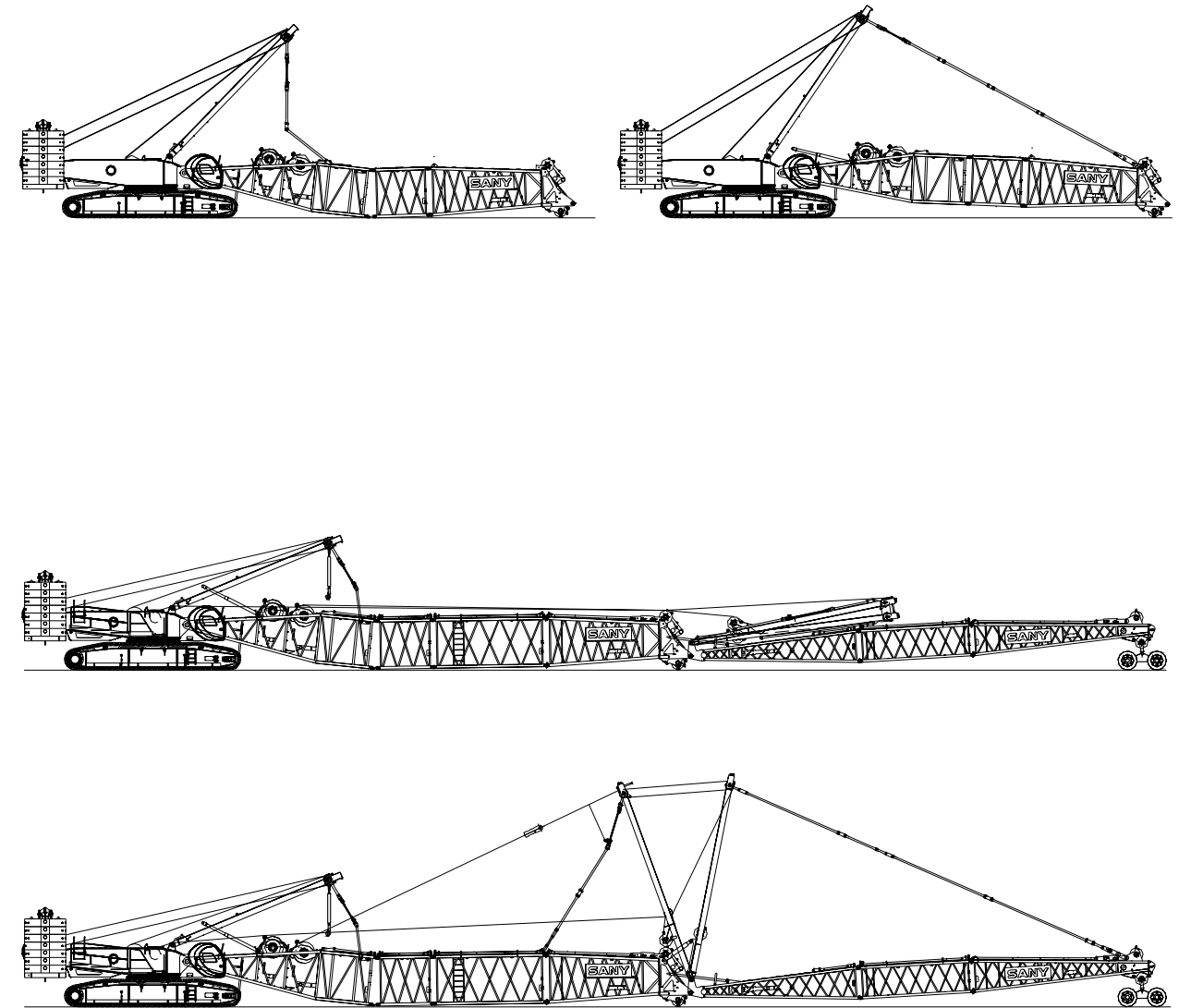

SELF-ASSEMBLY DIAGRAM

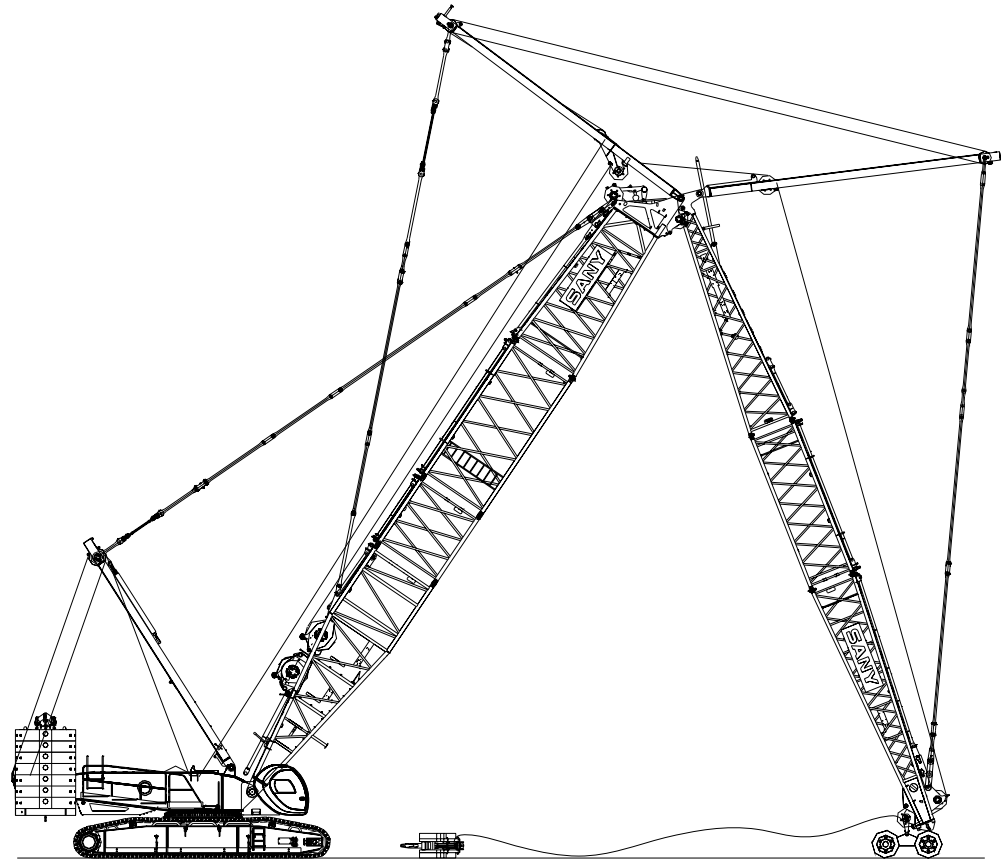

3) Installation of fixed jib operating condition boom

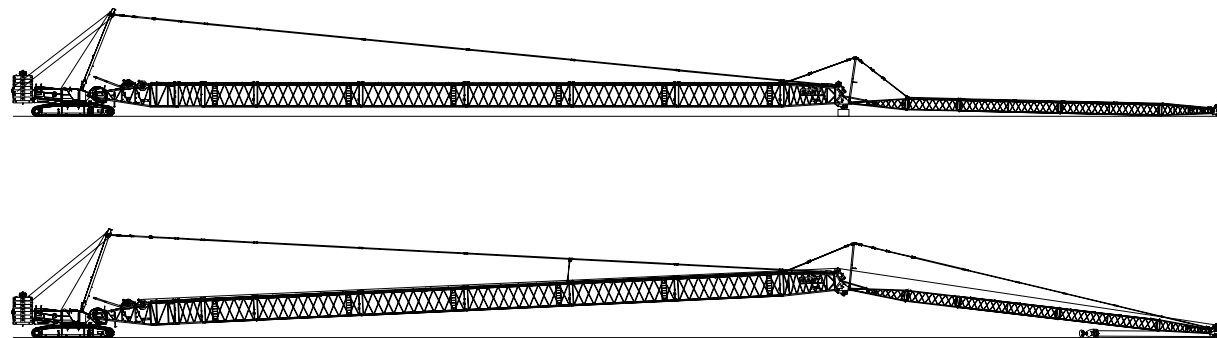

SELF-ASSEMBLY DIAGRAM

4) Installation of luffing jib + fixed jib operating condition boom

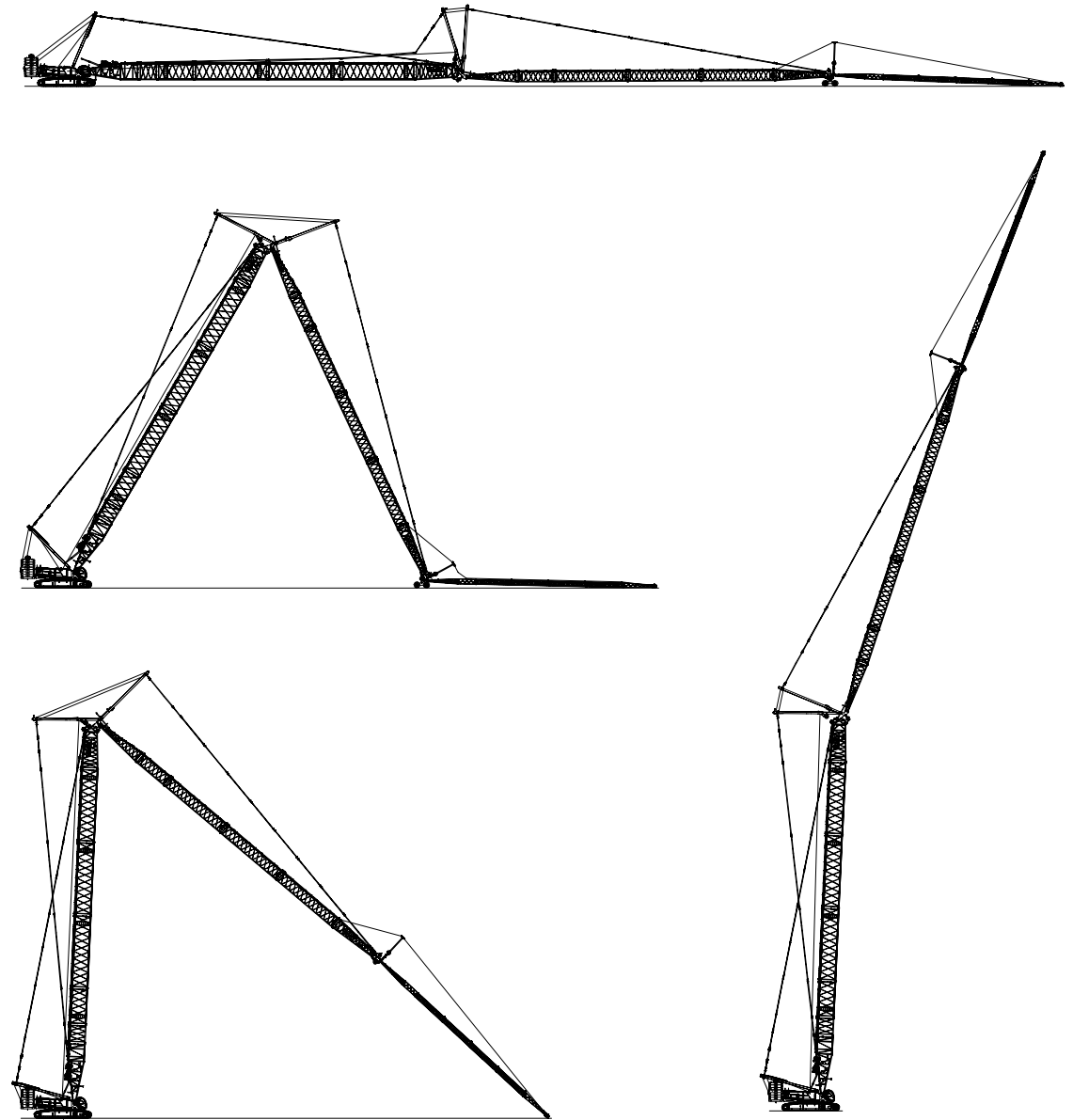

SCC8300

Superstructure	19
Undercarriage	21
Operation Devices	22
Safety Devices	23

SUPERSTRUCTURE

1) Engine

- Rated power: 298kW(400hP)/1800rpm
- Optional: QSM11(Tier 4)
- The engine is equipped with the 120V block heater, intake manifold grate heater, muffler, radiator and drive fan.
- The power transmission adopts the “One divides into three” transfer case and hydraulic tank. Two 12V maintenance-free batteries are in series. And the 1400CCA / -18 °C(0 °F), 24V/100A generator is adopted, equipping with a fuel tank with diesel capacity of 1050L.
- The engine monitoring instrument can display the water temperature, fuel level, accumulated working hours, oil pressure, engine speed, battery charge status, and voltage.

2) Electric Control System

- The advanced IFM controller, load moment indicator and closed-circuit surveillance system are adopted. And load moment indicator display (8.4”), closed-circuit monitor display (7”), and integrated instrument display (8”) are arranged within the operator’s direct field of vision; the CAN BUS is adopted between controller, display, control lever, engine and load moment indicator for data transfer.

3) Control Operation

- The load moment indicator display is mainly used to monitor the crane moment, load mass and lifting boom angle, and can show the rated loading capacity, working radius, and hook height etc. and consists of 8.4 inch color display, host, angle sensor, and force sensor.
- The monitor display mainly show the crane operating status and the control parameters of all monitoring points and alarm.
- There are three operating handles for left and right armrest boxes. The handle actions can be switched through the handle function key and the combined instrument can real-time display the information.

- There is a three-color indicator light on the external top of cab, showing the red, yellow and green colors. If the green color occurs, it indicates the load value within the range of 0~90%; if yellow color, within 90%~100% and if red, more than 100%.
- Closed-circuit surveillance system: The operator in cab can monitor the winding situation of wire ropes of all winch mechanisms and equipment surrounding circumstances. There are five cameras, with two at the rear of platform. There is a boom luffing winch, a main hoisting winch and a auxiliary hoisting winch.
- Self-diagnosis system: the operator can check the corresponding fault code through the self-diagnostic system and then find the fault according to the fault code.
- Black box: To record the operator's operation and the equipment’s operating parameters.
- Swing and traveling alarm: The sound and light alarm can be given while swinging and traveling.
- Emergency stop button: If the emergency stop button is pressed, the lifting, luffing, swing and traveling etc. actions will be cut off and then the engine shuts down.

4) Alarm Display

- All alarm information, including wind speed, water temperature, oil temperature, fuel level, oil pressure, working hours, and engine speed will be displayed on the display in cab. High quality motor reducer with higher reliability.

5) Hydraulic System

- The hydraulic system includes: Lifting hydraulic system, traveling hydraulic system, swing hydraulic system, luffing hydraulic system, anti-tilting backwards hydraulic system, cooling system, auxiliary hydraulic system and servo hydraulic system.
- Features: The open circuit is applied for main system and the closed circuit is applied for swing system. It has the free slipping function. The electronic proportional control components are widely adopted. And the system has the inching function.

- There are three 800L oil return filters, as well as various pressure alarms and filter clogging alarms. A balance valve is added on each open motor. The 850L hydraulic tank is equipped with two heaters with the rated voltage of 120V and the power of 1.5kw.
- The cylinder anti-tilting backwards structure is adopted, with the greater amount of compression to result in the larger anti-tilting force. The maximum output force of anti-tilting backwards cylinder of boom is 41t and of front mast of luffing jib is 31t. Fault self-diagnosis system: the operator can find the corresponding fault code through the fault self-diagnostic system and then find the fault according to the fault code.

6) Main And Auxiliary Hoisting Mechanism

- The planetary gear reducer driven by the variable hydraulic motor is adopted to achieve the lifting and lowering of main and vice winches, with the winch speed of 0-142 m / min and with stepless speed regulation allowed, having the excellent inching performance. The multi-layer winding without confused ropes can be achieved through the fold line drum. The reducer is concealed, which is characterized by the space-saving, low noise, high efficiency and long life.

Name	Wire diameter (mm)	Wire length (mm)	Rated single line pull (T)	Wire speed (m/min)
Main hoisting	28	710	15	142
Auxiliary hoisting	28	540	15	141

7) Luffing Mechanism

- Including: Boom luffing mechanism and jib luffing mechanism.
- The fold line drum is adopted and the reducer is concealed, with closed circuit. The power can be supplied through the changing over by the changeover valve; a variety of compound actions can be achieved. The stepless speed regulation is adopted, having the better inching performance.

Name	Wire diameter (mm)	Wire length (mm)	Rated single line pull (T)	Wire speed (m/min)
Boom luffing	26	360	13.8	132
Jib luffing	20	410	8	128

8) Swing Mechanism

- Swing part: It is driven by the large-displacement single motor reducer, with the swing speed of 0-1.85r/min, having the median free slipping function, to supply the 360° rotation. When the handle is at the middle position and there is no swing speed, the brake will close and the swing is at the locking state. However, the swing action can be forcedly locked through the rocker switch.
- Swing ring device: The three-row roller swing ring is adopted.

9) Counterweight System

- Central counterweight: 57 tons; with four counterweight and two counterweight trays.
- Machine rear counterweight: 128 tons, with fourteen counterweight and one counterweight tray.

Series 1			
Qty.	Load	Piece weight (t)	Total weight (t)
8	Counterweight block	8.0	64.0
1	Rear counterweight tray	16.0	16.0
Series 1 Total weight			80.0

Series 2			
Qty.	Load	Piece weight (t)	Total weight (t)
4	Counterweight block	8.0	32.0
2	Central counterweight frame	12.5	25.0
14	Counterweight block	8.0	112.0
1	Rear counterweight tray	16.0	16.0
Series 2 Total weight			185.0

10) Cab

- It is of fully-closed steel frame structure, with tempered glasses at front and sides and with the GE structural panel at top, having the better good transparency, high strength and high wear resistance. The indoor noise is low (<85dB) and the control device, instrumentation, fire fighting alarm devices and closed-circuit surveillance systems are in the cab, as well as 24V powered USB sockets. The cab meets the requirement of ergonomics design. The cab can be pitched up to 25 degrees.

UNDERCARRIAGE

1) Track Shoe

The track shoe width is 1200mm. The ideal tension can be achieved through adjusting the hydraulic cylinder in the track traveling device and regulating the number of shims.

2) Base

It is of high-strength steel welded frame structure, connecting with the track frame through the hydraulic cylinder drive power pins.

3) Traveling Speed

There are two speeds for variable motor: High speed: 0 ~ 1.3 km / h; low speed: 0 ~ 0.5 km / h; each speed is of continuously variable transmission.

OPERATION DEVICES

1) Boom

- The operation equipments and luffing supports are made of high-strength steel pipe and high-strength steel plate; the cast iron pulley is adopted on the boom and nylon pulley as luffing pulley. There are four lifting points and many stacking base plates on the boom frame.
- Boom NO.2825A.
- The boom is of space truss structure, welded by the steel pipe, with the boom tip and root strengthened with steel plate.
- The basic boom length is 20m, including 10m boom base, 3m boom insert and 7m boom tip.
- Optional boom system: 6m insert and 12m boom insert, with longest length up to 92m.
- Boom extension can be assembled.
- Optional combined boom NO.2825A/2316A.
- The length of basic combined boom is 58m, with longest length of 100m.
- Basic boom consists of 10m Boom NO.2825A base, 3m boom insert NO.2825A, 6m boom insert NO.2825A, 12m boom insert INO.2825A, 12m tapered insert NO.2825A / NO.2316A, and 9m jib tip NO.2316A.
- Other optional parts that can be assembled on the basic boom include 12m jib insert NO.2316A and 12m jib insert NO.2316A.

2) Boom Luffing Mast

- With door-shaped bracket structure, and welded with high-strength steel plate, with middle part strengthened with beam.

3) Fixed Jib

- With spatial truss structure and welded with steel pipe.
- There are three types for fixed jib: Conventional fixed jib, heavy fixed jib, and light fixed jib.

4) I.Conventional Fixed Jib No.1412A

- The length of conventional fixed jib is 13m~42m. All parts can be placed in the 40 feet open container, with models of some parts same with that of other parts of Sany.

- Components: 6.5m fixed jib base, 6m insert, 11.5m insert and 6.5m fixed jib tip.
- There are three 10° / 20° / 30° types of angle with boom NO.2825A.

5) II.Heavy Fixed Jib No.2316A

- The length of heavy fixed jib is 12m ~ 18m. The bracket can be transported together with the jib base.
- Components: 3m fixed jib base, 6m luffing jib insert and 9m luffing jib tip.
- There are three 10° / 15° / 20° types of angle with boom NO.2825A.

6) III.Light Fixed Jib NO.0908A

- The length of light fixed jib is 13m ~ 37m. It is mainly assembled on the combined boom or luffing jib.
- Components: 5m fixed jib base, 3m insert, 6m insert and 5m fixed jib tip.
- There are three 10° / 20° / 30° types of angle with jib NO.2316A.

7) Luffing Jib

- With spatial truss structure and welded with steel pipe.
- The length of luffing jib NO.2316A is 18m~66m.
- Components: 9m luffing jib base, 6m insert, 12m insert and 9m luffing jib tip.

8) Hook

- There is a baffle on each lifting hook to prevent the wire rope fall off.

Hook name	Maximum lifting capacity	Qty.	Number of pulleys	Rate	Weight of single part (t)
300T Hook	300	1	11	20	6.20
150T Hook	150	1	5	10	3.76
100T Hook	100	1	3	7	3.21
50T Hook	50	1	1	3	2.39
15T Ball hook	15	1	1	1	1.00

SAFETY DEVICES

1) Main And Auxiliary Hoisting Limiter

- The over-hoist limit device limit switch is used to prevent the over hoisting of hook. When the lifting hook is up to a certain height, the limit switch acts and at the same time the buzzer on the control panel in cab alarms, so the lifting action will automatically stop. At this time, the hook lowering is allowed only.

2) Lowering Limiter of Main And Auxiliary Winches

If the last three wraps of wire rope winding on the reel remains, the signal will be given by the wire rope detection system, so the hook lowering will automatically stop through the electrical control system and an alarm will be given from the buzzer and display in cab.

3) Erection Mode / Working Mode Change-Over Switch

- There are erection model and working model for the operation of crane, which ensures the safety protection to crane and also the easy disassembly of crane.
- Lifting boom / jib limit device.
- If the boom or jib angle is reached, the corresponding limit switch will act, so the buzzer will alarm and the boom / jib will automatically stop to limit the action of the luffing drum.

4) Winch Mechanism Brake

- The spring-loaded normally closed discs brake used for the brakes of all winch mechanisms are characterized by the larger braking force, maintenance-free, and long life.
- Boom warning light.
- It is installed at the top of boom.

5) Anemometer

- Installed at the top of boom and can be shown on the monitor in cab.
- Electronic Level gauge.
- Electronic Level gauge can display tilt angle of upper works on monitor.

6) Operation Release

- The crane operator must sit on the seat and pull up the operation release lever for this operation; if leaving the seat or pulling down the lever, all control handles and action switches will be locked.
- Engine power limit load adjustment and stall protection.
- The controller can monitor the engine power to prevent the engine stopping and stall.

7) Emergency Operating System

- emergency operation box with the independent circuit is adopted and connected with the solenoid valve through the connectors. In case of emergency, all lifting, luffing and swing etc. main operations will be achieved.

8) Remote Monitoring System

- The anti-tilting backwards device works when the luffing jib and boom extension angle is 10° .

SCC8300

Operating conditions combination	25
H operating conditions boom combination	27
HJ operating conditions	31
LJ operating conditions	35
FJ operating conditions	39
FJ _n operating conditions	43
HJFJ operating conditions	47

OPERATING CONDITIONS COMBINATION

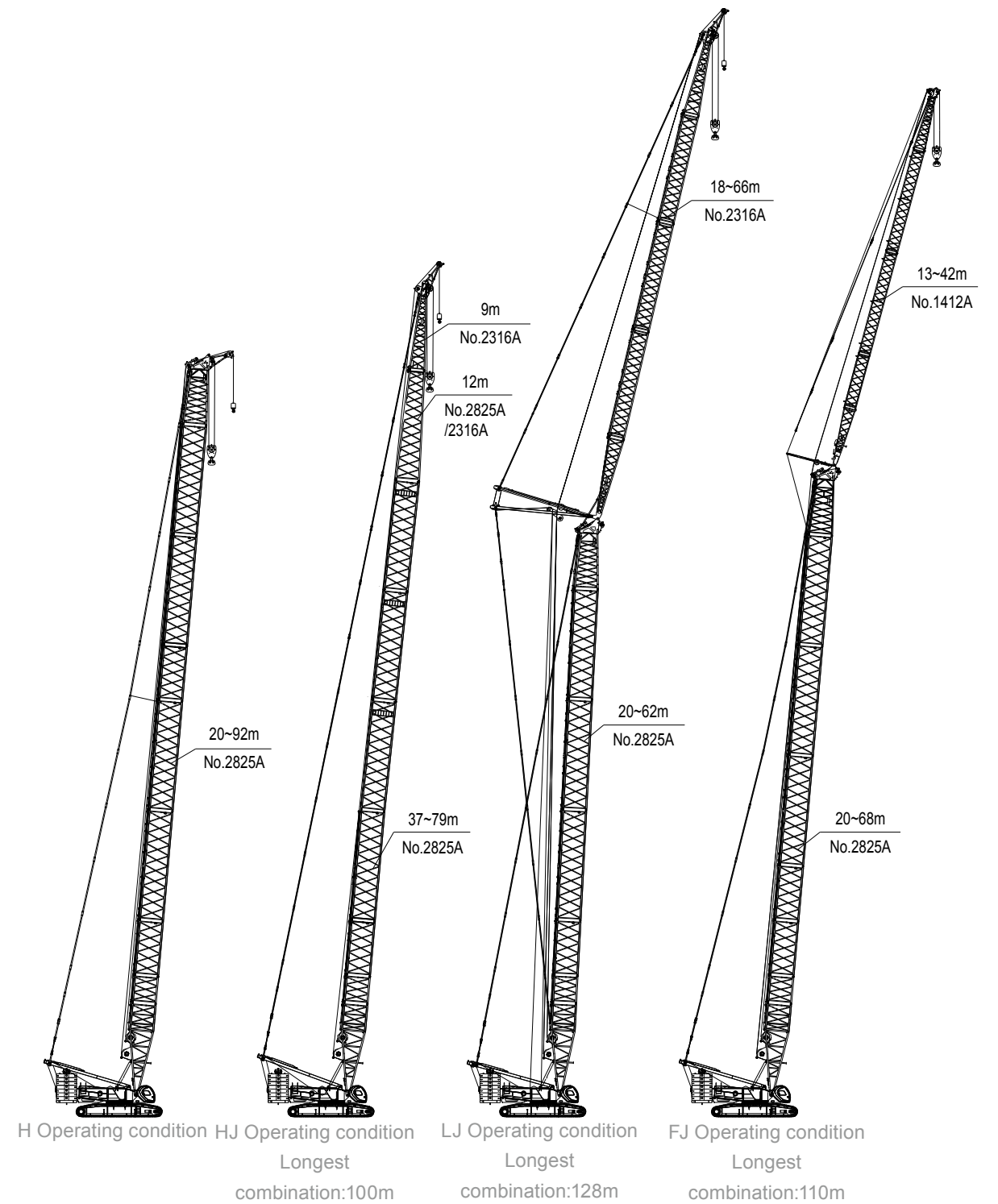

OPERATING CONDITIONS COMBINATION

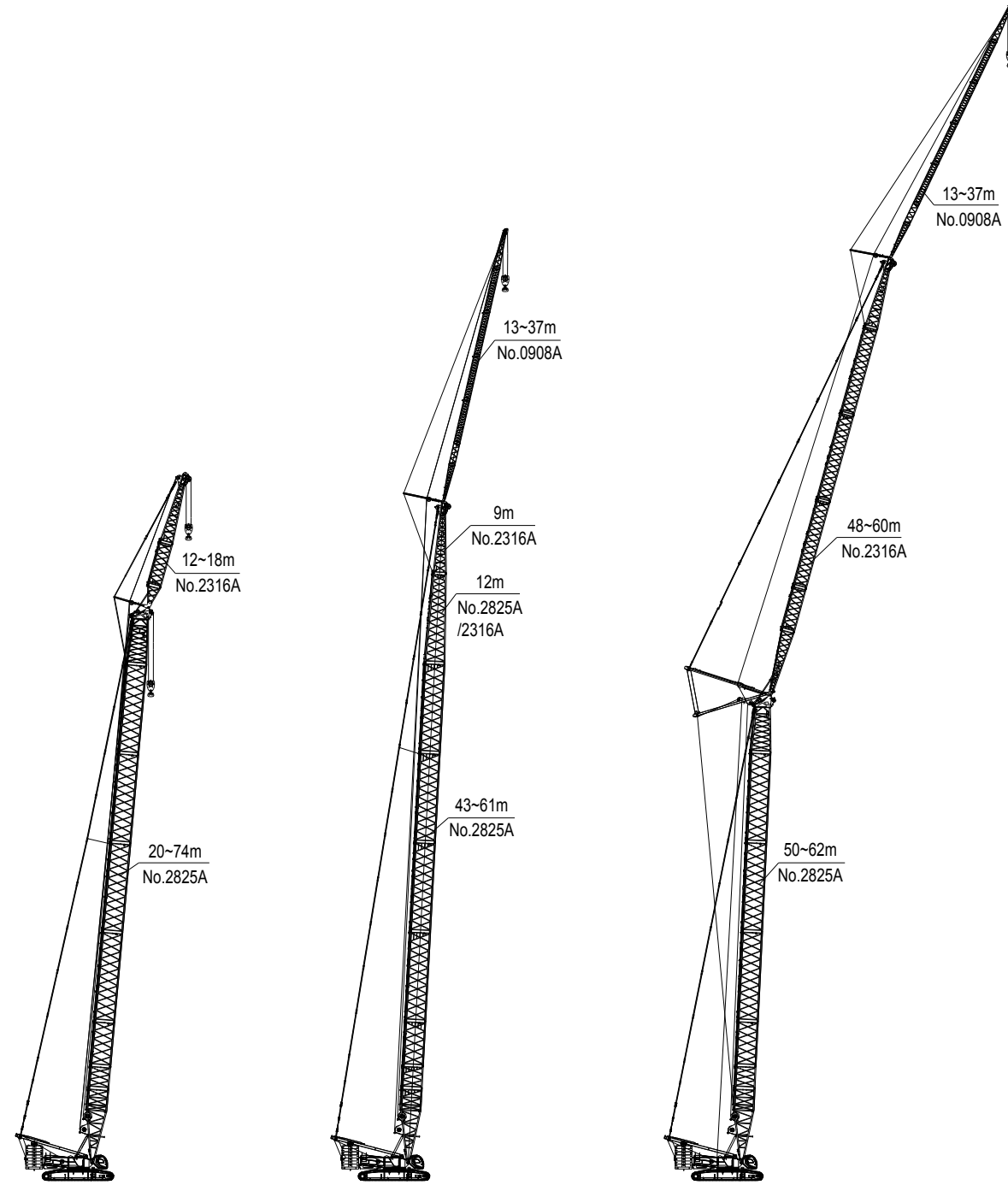

FJH Operating condition
Longest
combination:92m

HJFJ Operating condition
Longest
combination:119m

LJFL Operating condition
Longest
combination:159m

H OPERATING CONDITIONS BOOM COMBINATION

Boom length (m)	Boom insert		
	6 m	12ml	12mll
20	—	—	—
26	1	—	—
32	2	—	—
38	1	1	—
44	2	1	—
50	1	2	—
56	2	2	—
62	1	2	1
68	2	2	1
74	1	3	1
80	2	3	1
86	1	3	2
92	2	3	2

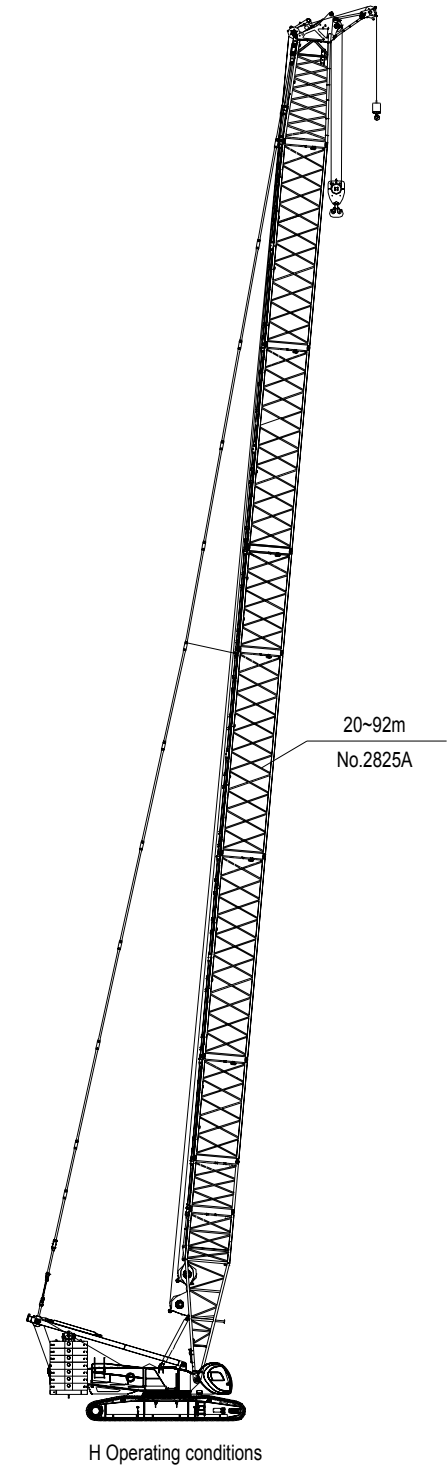

H OPERATING CONDITIONS RANGE DIAGRAM

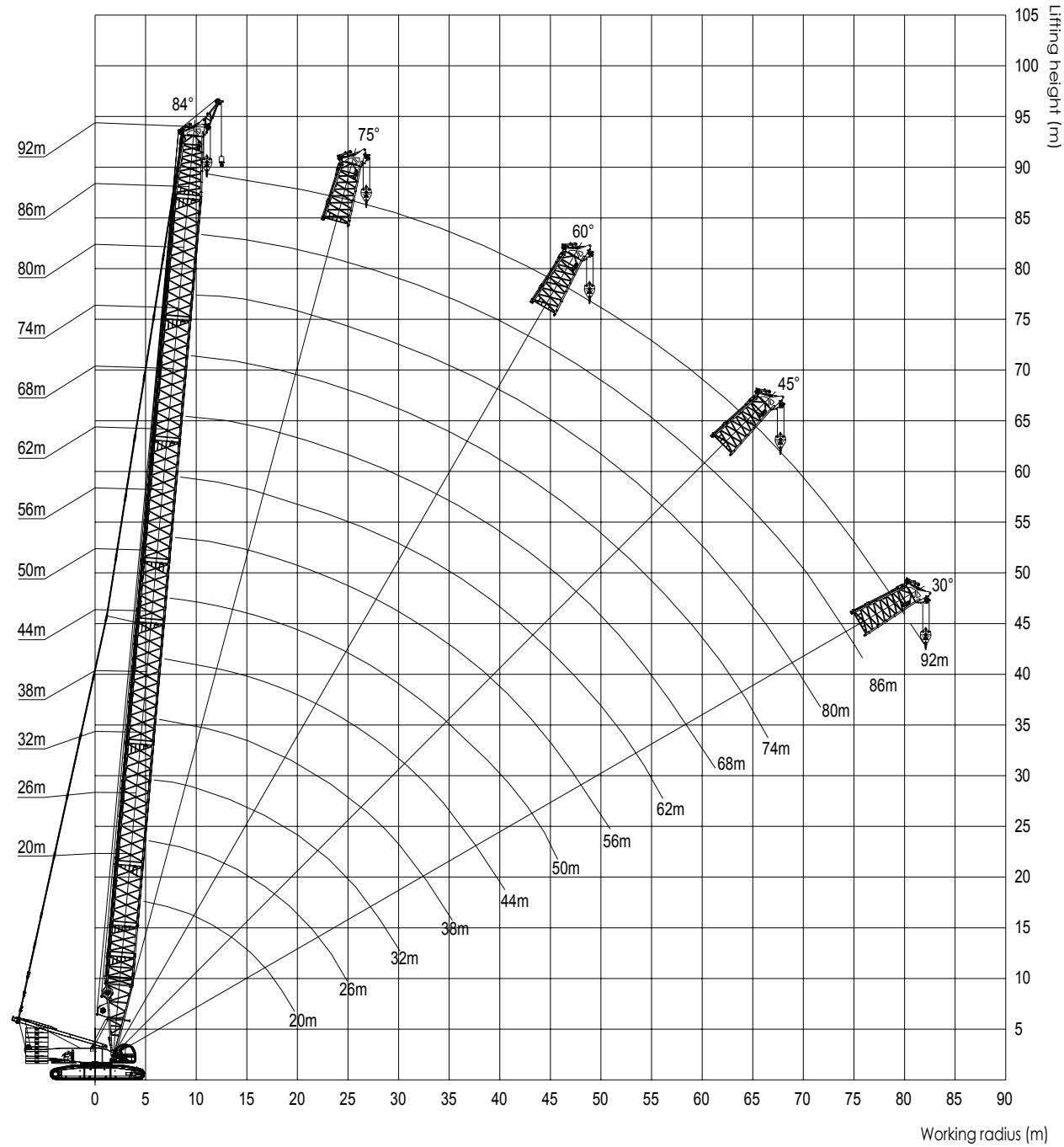

H OPERATING CONDITIONS LOAD CHART

SCC8300 H operation condition (series 2) load chart

Boom No.2825A 128t + 57t 360°

Unit: (t)

Radius (m)	20	32	44	56	68	80	92	Radius (m)
5	300.0	-	-	-	-	-	-	5
6	260.0	-	-	-	-	-	-	6
7	236.0	225.0	-	-	-	-	-	7
8	205.0	195.0	184.0	-	-	-	-	8
9	182.0	179.0	166.0	149.5	-	-	-	9
10	163.2	160.6	148.0	138.0	-	-	-	10
12	136.0	133.7	124.3	114.0	105.0	93.6	-	12
14	116.4	114.0	109.1	100.3	92.4	87.2	67.9	14
16	100.3	99.7	94.2	87.1	80.6	74.5	62.5	16
18	85.4	85.5	82.6	76.7	71.1	65.9	58.4	18
20	-	74.2	73.2	68.2	63.3	58.7	55.1	20
24	-	57.8	57.1	55.2	51.3	47.6	43.4	24
28	-	46.6	46.0	45.0	42.5	39.3	35.7	28
32	-	-	38.0	37.0	35.7	32.8	29.5	32
36	-	-	31.9	31.0	29.8	27.7	24.8	36
40	-	-	27.1	26.2	25.0	23.6	20.8	40
44	-	-	-	22.3	21.2	20.0	17.5	44
48	-	-	-	19.1	18.1	16.8	14.7	48
52	-	-	-	-	15.4	14.2	12.3	52
56	-	-	-	-	13.1	11.9	10.3	56
60	-	-	-	-	11.1	10.0	8.4	60
64	-	-	-	-	-	8.3	6.8	64
68	-	-	-	-	-	6.8	5.4	68
72	-	-	-	-	-	-	3.9	72
76	-	-	-	-	-	-	2.5	76
78	-	-	-	-	-	-	2.0	78
Lines	20	17	14	10	9	7	5	Lines

※ Note:

1. The actual weight is a value that the rated weight in this chart is subtracted by the weights of the hooks, hangers, and wire ropes winding on the hooks and on the boom head.;
2. The rated load in chart refers to a value under the condition that the heavy load is lifted slowly and smoothly from the level and hard soil ground.

H OPERATING CONDITIONS LOAD CHART

SCC8300 H operation condition (series 1) load chart

Boom No.2825A 80t + 0t 360°

Unit: (t)

Radius (m)	20	26	32	38	44	50	56	62	68	74	Radius (m)
6	230.1	220.0	-	-	-	-	-	-	-	-	6
7	197.3	180.7	166.5	153.9	-	-	-	-	-	-	7
8	164.9	152.9	142.3	132.8	124.3	-	-	-	-	-	8
9	141.2	132.1	124.0	116.4	109.6	103.3	97.5	-	-	-	9
10	123.1	116.0	109.5	103.4	97.8	92.5	87.6	83.0	-	-	10
12	94.3	92.7	88.3	83.9	79.9	75.9	72.3	68.8	65.4	62.2	12
14	74.8	75.0	73.4	70.1	67.0	63.9	61.0	58.1	55.5	52.8	14
16	61.2	61.6	61.5	59.7	57.2	54.7	52.3	49.9	47.7	45.4	16
18	51.3	51.8	51.8	51.5	49.6	47.4	45.4	43.3	41.4	39.4	18
20	-	44.3	44.4	44.1	43.5	41.6	39.8	38.0	36.3	34.5	20
24	-	33.4	33.7	33.4	33.1	32.6	31.3	29.8	28.3	26.8	24
26	-	-	29.7	29.5	29.2	28.7	27.9	26.5	25.2	23.8	26
30	-	-	23.5	23.3	23.1	22.6	22.2	21.3	20.1	18.8	30
32	-	-	-	20.9	20.7	20.2	19.7	19.1	18.0	16.8	32
34	-	-	-	18.7	18.5	18.1	17.6	17.0	16.1	15.0	34
36	-	-	-	-	16.6	16.2	15.8	15.2	14.4	13.3	36
40	-	-	-	-	13.4	13.0	12.6	12.1	11.5	10.5	40
42	-	-	-	-	-	11.7	11.3	10.7	10.2	9.3	42
44	-	-	-	-	-	10.5	10.1	9.5	9.0	8.2	44
46	-	-	-	-	-	-	9.0	8.4	7.9	7.1	46
50	-	-	-	-	-	-	7.0	6.5	6.0	5.3	50
52	-	-	-	-	-	-	-	5.7	5.1	4.5	52
56	-	-	-	-	-	-	-	4.1	3.6	3.0	56
58	-	-	-	-	-	-	-	-	3.0	2.3	58
lines	20	19	14	13	10	10	9	8	7	6	lines

※ Note:

1. The actual weight is a value that the rated weight in this chart is subtracted by the weights of the hooks, hangers, and wire ropes winding on the hooks and on the boom head.;
2. The rated load in chart refers to a value under the condition that the heavy load is lifted slowly and smoothly from the level and hard soil ground.

HJ OPERATING CONDITIONS

Series No.	1	2	3	4	5	6	7	8
Boom length	Boom base 10m	Boom 3m Boom insert 3m	Boom 6m Boom insert 6m	Boom 12m Boom insert I 12m	Boom 12m Boom insert II 12m	Boom tapered insert 12m	Luffing jib tip 9m	Boom mid-point suspension cable I 2.17m
58	1	1	0	2	0	1	1	0
61	1	0	1	2	0	1	1	0
64	1	1	1	2	0	1	1	0
67	1	0	0	3	0	1	1	0
70	1	1	0	3	0	1	1	0
73	1	0	1	3	0	1	1	0
76	1	1	1	1	2	1	1	1
79	1	0	0	2	2	1	1	1
82	1	1	0	2	2	1	1	1
85	1	0	1	2	2	1	1	1
88	1	1	1	2	2	1	1	1
91	1	0	0	3	2	1	1	1
94	1	1	0	3	2	1	1	1
97	1	0	1	3	2	1	1	1
100	1	1	1	3	2	1	1	1

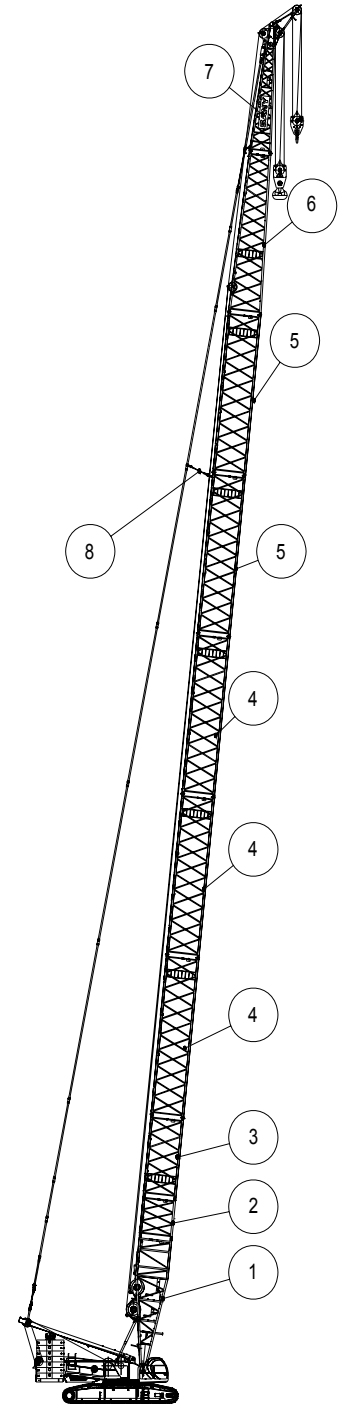

HJ Operating condition

HJ OPERATING CONDITIONS RANGE DIAGRAM

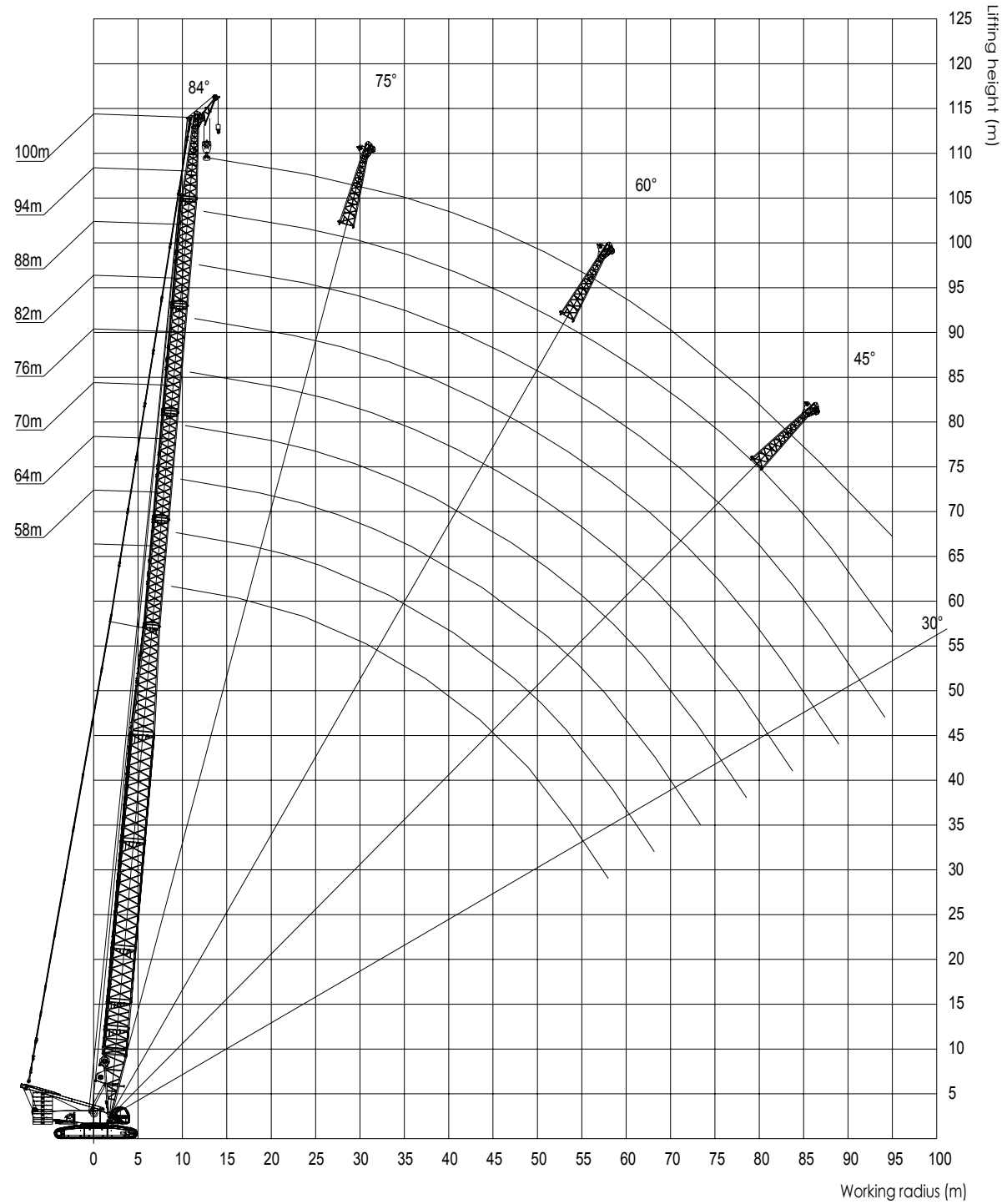

HJ OPERATING CONDITIONS LOAD CHART

SCC8300 HJ operation condition (series 2) load chart

Boom No.2825A No.2316A 128t + 57t 360°

Unit: (t)

Radius (m)	58	61	64	70	76	82	88	94	100	Radius (m)
9	111.2	111.2	111.2	-	-	-	-	-	-	9
10	111.2	108.8	106.4	103.6	93.4	-	-	-	-	10
12	106.1	104.8	103.5	97.3	91.2	79.6	70.2	59.4	-	12
14	97.5	96.5	95.4	92.3	89.4	77.5	69.4	58.1	52.4	14
16	83.2	83.3	83.3	80.9	78.5	76.3	67.5	57.4	50.3	16
18	74.3	74.0	73.7	71.7	69.7	67.9	66	56.9	49.7	18
22	60.1	59.6	59.2	57.9	56.4	55.1	53.7	52.3	47.3	22
26	50.4	49.6	48.9	47.9	46.8	45.8	44.7	43.6	42.5	26
30	41.2	41.0	40.9	40.4	39.5	38.7	37.8	36.9	36.0	30
34	34.5	34.3	34.1	34.2	33.8	33.1	32.4	31.6	30.8	34
38	29.2	29.1	28.9	28.9	28.9	28.6	28.0	27.3	26.6	38
42	25.0	24.9	24.7	24.8	24.7	24.7	24.4	23.7	23.1	42
46	21.6	21.4	21.3	21.4	21.3	21.3	21.1	20.7	20.2	46
50			18.5	18.5	18.4	18.4	17.7	17.6	16.7	50
54				15.5	15.1	15.0	14.5	14.5	13.4	54
58					12.1	12.3	11.6	11.6	10.6	58
62	-	-	-			10.0	9.1	9.1	8.2	62
66	-	-	-	-			7.1	7.1	6.2	66
70	-	-	-	-	-		5.3	5.3	4.3	70
74	-	-	-	-	-	-		3.7	2.7	74
78	-	-	-	-	-	-			1.4	78
82	-	-	-	-	-	-	-			82
84	-	-	-	-	-	-	-	-		84
88	-	-	-	-	-	-	-	-		88
92	-	-	-	-	-	-	-	-	-	92
Lines	8	8	8	7	7	6	5	4	4	Lines

※ Note:

1. The actual weight is a value that the rated weight in this chart is subtracted by the weights of the hooks, hangers, and wire ropes winding on the hooks and on the boom head.
2. The rated load in chart refers to a value under the condition that the heavy load is lifted slowly and smoothly from the level and hard soil ground.

HJ OPERATING CONDITIONS LOAD CHART

SCC8300 HJ operation condition (series 1) load chart

Boom No.2825A No.2316A 80t + 0t 360°

Unit: (t)

Radius (m)	64	70	76	82	88	Radius (m)
10	88.8	84.6	80.7	77.0	-	10
12	73.5	70.3	67.2	64.3	61.5	12
14	62.2	59.6	57.1	54.7	52.3	14
16	53.5	51.4	49.2	47.2	45.1	16
18	46.6	44.8	42.9	41.1	39.3	18
20	41.1	39.4	37.7	36.1	34.5	20
22	36.4	35.0	33.4	32.0	30.4	22
24	32.5	31.2	29.8	28.4	27.0	24
26	29.2	28.0	26.6	25.4	24.0	26
28	26.4	25.2	23.9	22.7	21.4	28
30	23.9	22.7	21.5	20.4	19.2	30
32	21.6	20.6	19.4	18.3	17.2	32
34	19.4	18.7	17.6	16.5	15.4	34
36	17.5	17.0	15.9	14.9	13.8	36
38	15.8	15.3	14.4	13.4	12.3	38
40	14.3	13.8	13.0	12.0	11.0	40
42	12.9	12.4	11.8	10.8	9.8	42
44	11.7	11.2	10.6	9.7	8.7	44
46	10.6	10.1	9.5	8.7	7.7	46
48	9.6	9.1	8.5	7.7	6.7	48
50	8.7	8.2	7.6	6.8	5.9	50
52	7.8	7.3	6.7	6.0	5.1	52
54	7.0	6.5	5.9	5.3	4.3	54
56	6.3	5.8	5.2	4.6	3.6	56
58	-	5.1	4.5	3.9	3.0	58
60	-	4.5	3.9	3.3	2.4	60
62	-	3.9	3.3	2.7	1.8	62
Lines	6	6	6	6	5	Lines

※ Note:

1. The actual weight is a value that the rated weight in this chart is subtracted by the weights of the hooks, hangers, and wire ropes winding on the hooks and on the boom head.
2. The rated load in chart refers to a value under the condition that the heavy load is lifted slowly and smoothly from the level and hard soil ground.

LJ OPERATING CONDITIONS

Jib length(m)	Insert		Boom length and angle
	6m	12m	
18	-	-	20~62m 87° 83° 75° 65°
24	1	-	
30	2	-	
36	1	1	
42	2	1	
48	1	2	
54	2	2	
60	1	3	
66	2	3	

※ Note

1. 9m jib base and 9m jib tip form the 18m basic jib combination; the boom angles of 87°, 83°, 75°, and 65° are fixed valves.

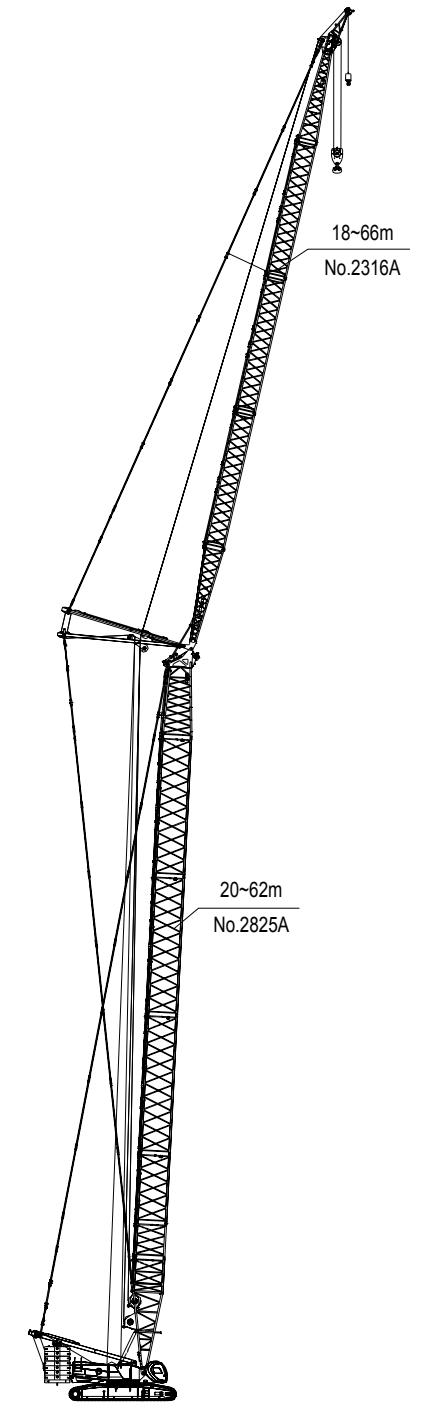

LJ Operating condition
Longest combination:
128m

LJ OPERATING CONDITION RANGE DIAGRAM

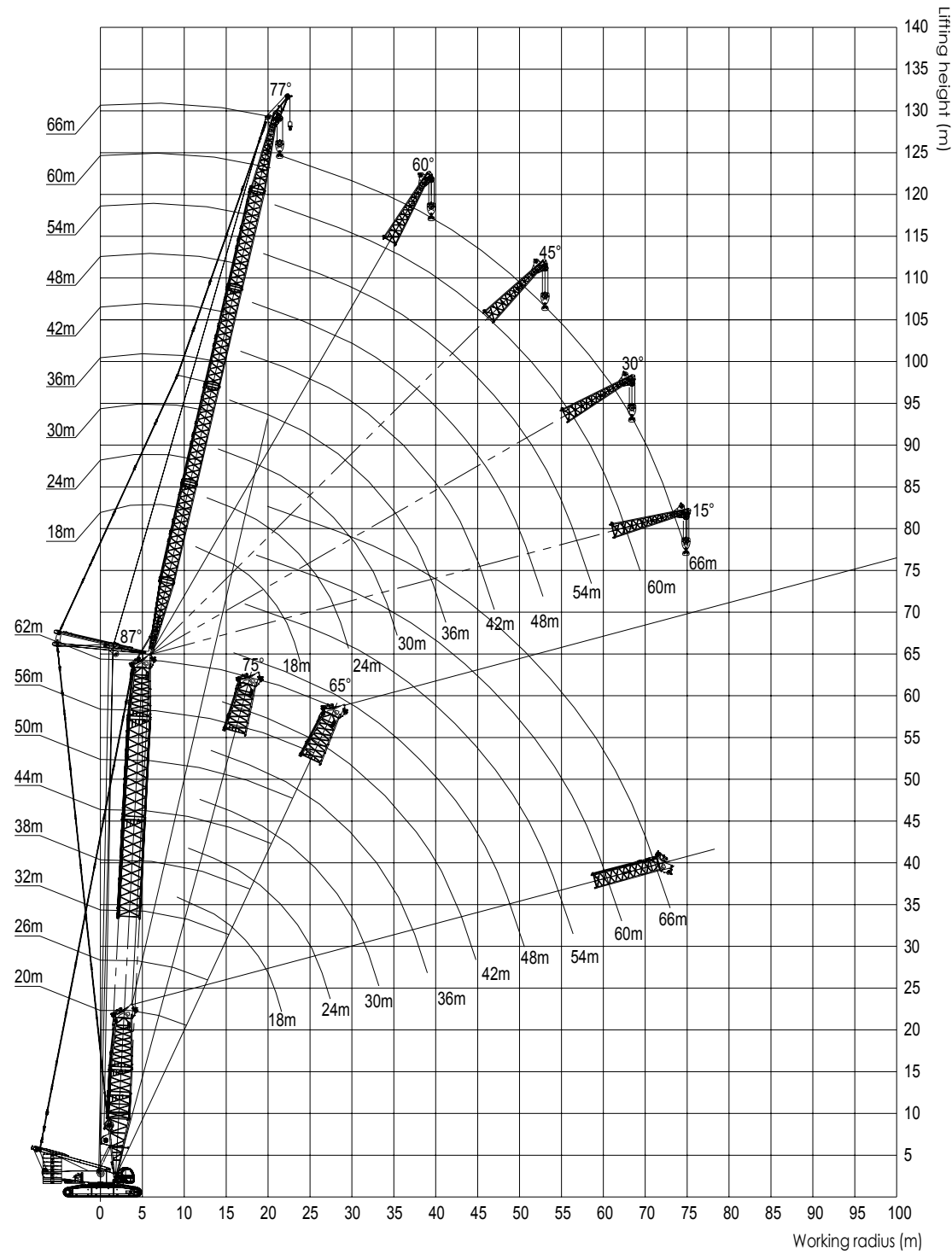

LJ OPERATING CONDITION 87° BOOM LOAD CHART

SCC8300 Luffing jib operating condition (20m boom) load chart

BoomNo.2825A/Jib No.2316A 128t + 57t 360°

Unit: (t)

Radius (m)	18	24	30	36	42	48	54	60	66	Radius (m)
9	109.5	113.9	-	-	-	-	-	-	-	9
10	99.7	103.4	-	-	-	-	-	-	-	10
12	75.4	84.0	92.6	76.4	-	-	-	-	-	12
14	61.7	67.5	73.2	64.6	55.9	49.5	-	-	-	14
16	50.4	55.3	60.2	53.9	47.6	48.3	48.9	-	-	16
18	-	47.1	51.5	46.5	41.6	40.9	40.1	39.2	-	18
20	-	39.8	45.1	40.1	35.2	34.7	34.2	33.7	33.1	20
22	-	36.4	40.3	35.0	29.7	29.3	28.9	28.5	28.1	22
24	-	-	36.1	31.7	27.3	26.8	26.2	25.7	25.2	24
26	-	-	32.3	28.2	24.1	23.4	22.8	22.1	21.5	26
28	-	-	29.5	25.6	21.8	21.1	20.5	19.9	19.3	28
30	-	-	-	22.8	20.2	19.8	19.3	18.9	18.5	30
32	-	-	-	21.0	19.0	18.4	17.7	17.1	16.5	32
34	-	-	-	-	17.6	17.0	16.4	15.8	15.2	34
36	-	-	-	-	16.2	15.8	15.3	14.9	14.4	36
38	-	-	-	-	15.1	14.9	14.6	14.4	14.1	38
40	-	-	-	-	-	13.8	13.5	13.2	12.9	40
42	-	-	-	-	-	12.7	12.9	12.9	12.5	42
44	-	-	-	-	-	-	12.0	12.0	12.0	44
46	-	-	-	-	-	-	11.3	11.3	11.2	46
48	-	-	-	-	-	-	9.1	9.1	9.1	48
50	-	-	-	-	-	-	-	8.4	8.4	50
52	-	-	-	-	-	-	-	6.5	6.5	52
54	-	-	-	-	-	-	-	4.7	4.7	54
56	-	-	-	-	-	-	-	-	4.1	56
58	-	-	-	-	-	-	-	-	2.7	58
60	-	-	-	-	-	-	-	-	-	60
Lines	8	8	7	6	4	4	4	3	3	Lines

※ Note

1. The actual weight is a value that the rated weight in this chart is subtracted by the weights of the hooks, hangers, and wire ropes winding on the hooks and on the boom head.
2. The rated load in chart refers to a value under the condition that the heavy load is lifted slowly and smoothly from the level and hard soil ground.

LJ OPERATING CONDITION 87° BOOM LOAD CHART

SCC8300 Luffing jib operating condition (62m boom) load chart

BoomNo.2825A/Jib No.2316A 128t + 57t 360°

Unit: (t)

Radius (m)	18	24	30	36	42	48	54	60	66	Radius (m)
12	81.1	78.5	-	-	-	-	-	-	-	12
14	73.1	71.6	67.1	59.8	-	-	-	-	-	14
16	66.8	65.1	62.4	57.4	51.8	45.4	-	-	-	16
18	61.5	59.8	57.8	54.7	49.1	44.3	38.5	33.0	-	18
20	56.7	55.5	54.1	51.2	47.1	42.5	38.0	31.6	-	20
22	-	51.5	50.2	48.6	44.5	40.8	36.8	30.2	23.6	22
24	-	48.3	46.9	45.5	42.4	38.9	34.9	29.2	23.4	24
26	-	-	42.3	42.5	39.9	36.7	33.2	27.9	22.6	26
28	-	-	38.9	38.7	36.9	34.2	31.2	26.5	21.8	28
30	-	-	35.5	35.6	34.0	31.8	29.3	25.3	21.2	30
32	-	-	-	32.4	31.6	29.5	27.4	24.0	20.6	32
34	-	-	-	30.2	29.0	27.5	25.6	22.8	20.0	34
36	-	-	-	-	26.8	25.5	23.8	21.6	19.4	36
38	-	-	-	-	24.7	23.5	22.3	20.6	18.8	38
40	-	-	-	-	22.7	21.8	20.1	19.2	18.3	40
42	-	-	-	-	-	20.2	19.3	18.5	17.7	42
44	-	-	-	-	-	18.8	17.9	17.6	17.2	44
46	-	-	-	-	-	17.3	17.2	17.2	16.7	46
48	-	-	-	-	-	-	16.5	16.4	16.3	48
50	-	-	-	-	-	-	16.1	16.0	16.0	50
52	-	-	-	-	-	-	-	14.6	14.4	52
54	-	-	-	-	-	-	-	13.3	13.0	54
56	-	-	-	-	-	-	-	11.9	11.6	56
58	-	-	-	-	-	-	-	-	10.4	58
60	-	-	-	-	-	-	-	-	9.2	60
62	-	-	-	-	-	-	-	-	-	62
Lines	6	6	5	4	4	4	3	3	2	Lines

※ Note:

1. The actual weight is a value that the rated weight in this chart is subtracted by the weights of the hooks, hangers, and wire ropes winding on the hooks and on the boom head.
2. The rated load in chart refers to a value under the condition that the heavy load is lifted slowly and smoothly from the level and hard soil ground.

※ Note There are 87°, 83°, 75° and 65° for the angles between boom and horizontal plane.

FJ OPERATING CONDITIONS

Jib length(m)	Jib insert		Boom length and angle between boom and jib
	6m	11.5m	
13	-	-	20~68m 10° 20° 30°
19	1	-	
24.5	-	1	
30.5	1	1	
36	-	2	
42	1	2	

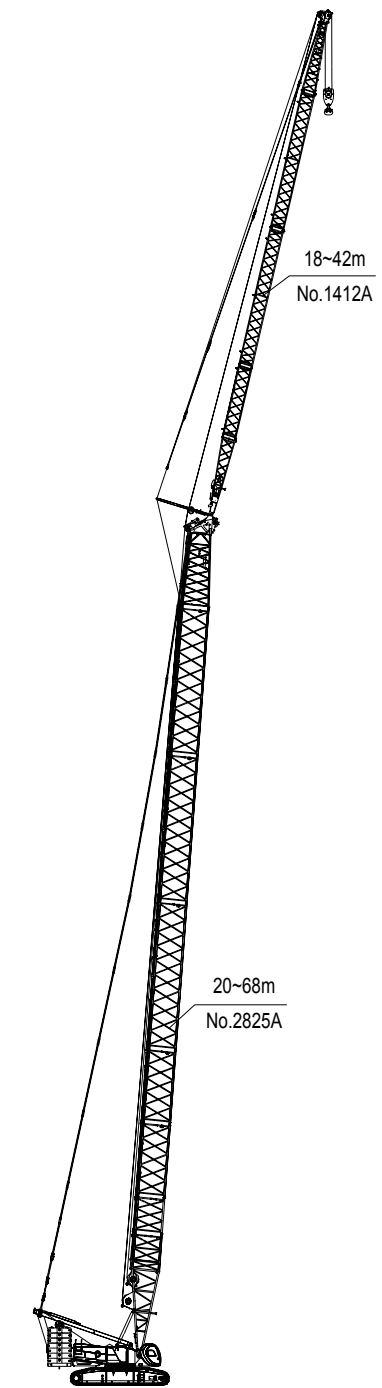

FJ Operating condition
Longest combination: 110m

FJ OPERATING CONDITION RANGE DIAGRAM

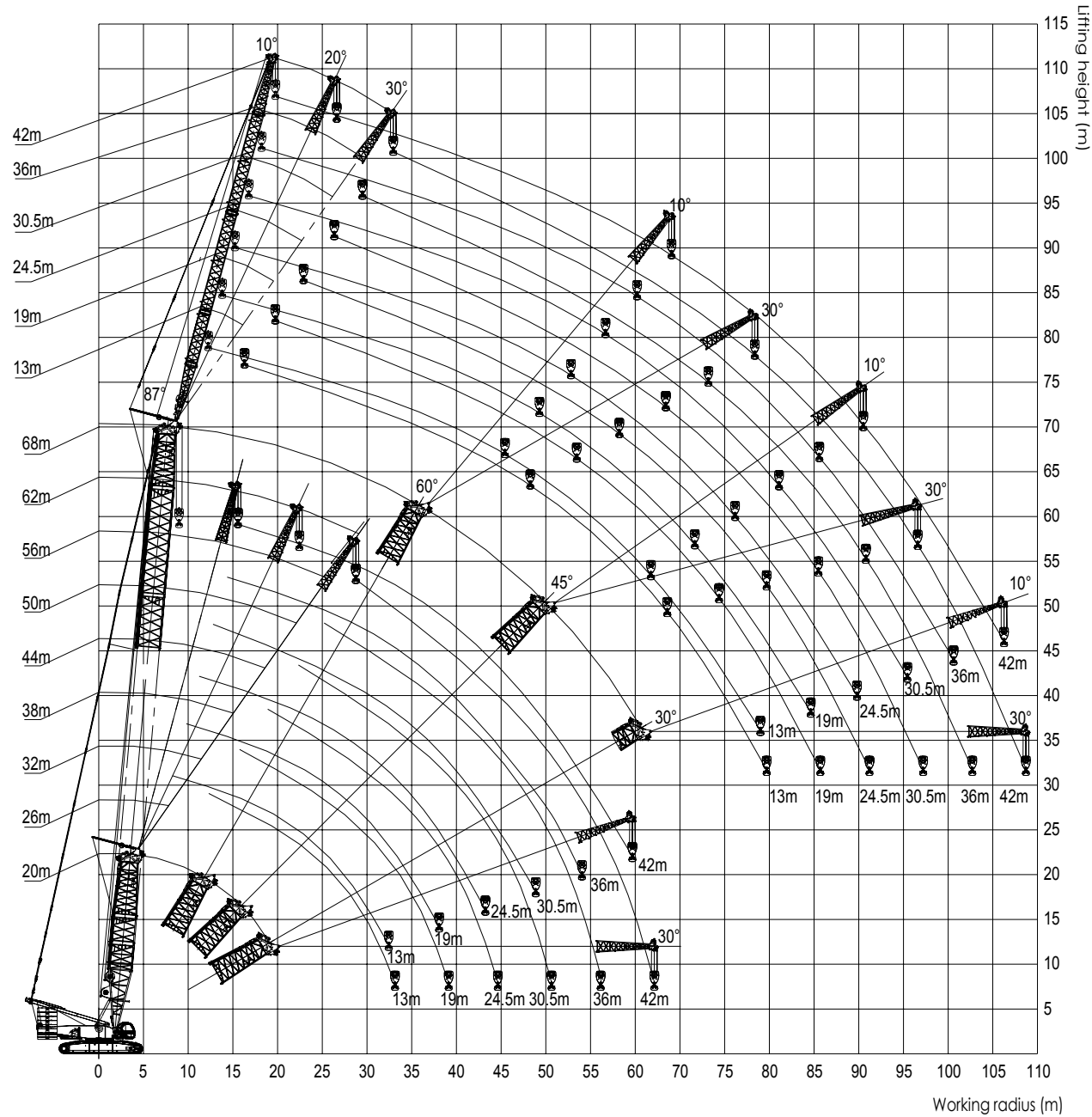

FJ OPERATING CONDITION LOAD CHART

SCC8300 10° between boom and jib and 13m fixed jib load chart

Boom No.2825A/Fixed jib No.2316A 128t + 57t 360°

Unit: (t)

Radius (m)	20	26	32	38	44	50	56	62	68	Radius (m)
9	58.9	60.2	-	-	-	-	-	-	-	9
10	54.3	56.9	59.5	61.0	-	-	-	-	-	10
11	50.0	52.7	55.4	58.6	59.0	-	-	-	-	11
12	45.9	47.6	51.3	56.0	57.1	57.9	59.3	-	-	12
14	41.3	43.2	48.0	52.1	54.7	55.7	56.3	55.6	54.8	14
16	37.2	39.3	43.6	48.3	51.1	52.5	52.8	53.2	52.8	16
18	34.1	36.2	40.4	44.2	47.0	48.4	48.6	50.3	50.6	18
20	31.3	34.2	37.5	41.0	43.6	45.2	46.2	47.4	48.3	20
22	28.5	31.2	34.3	37.9	40.3	42.1	43.2	44.6	46.0	22
24	26.3	29.7	32.5	35.0	37.6	39.4	41.5	42.3	43.6	24
26	24.3	27.6	30.6	32.8	35.3	37.4	39.6	40.7	41.9	26
28	22.7	25.8	28.6	31.0	34.2	36.0	37.9	38.6	40.0	28
30	-	24.2	27.0	29.5	31.9	34.1	35.8	36.8	37.7	30
32	-	22.9	25.5	27.9	30.2	32.4	33.5	35.0	35.6	32
34	-	21.6	24.1	26.5	28.7	30.8	32.3	33.8	33.2	34
36	-	-	23.0	25.2	27.4	29.4	30.5	31.8	30.6	36
38	-	-	21.9	24.1	26.2	28.1	28.6	29.4	28.2	38
40	-	-	21.0	23.0	25.0	26.7	26.5	27.3	26.1	40
44	-	-	-	21.3	23.1	24.4	23.9	23.3	22.4	44
48	-	-	-	19.8	21.5	21.0	20.5	19.9	19.3	48
52	-	-	-	-	18.7	18.2	17.7	17.1	16.6	52
56	-	-	-	-	-	15.8	15.3	14.7	14.1	56
60	-	-	-	-	-	-	13.2	12.6	12.1	60
64	-	-	-	-	-	-	-	10.8	10.3	64
68	-	-	-	-	-	-	-	9.2	8.6	68
72	-	-	-	-	-	-	-	-	7.2	72
Lines	4	5	4	5	4	4	4	4	4	Lines

※ Note:

1. The actual weight is a value that the rated weight in this chart is subtracted by the weights of the hooks, hangers, and wire ropes winding on the hooks and on the boom head.
2. The rated load in chart refers to a value under the condition that the heavy load is lifted slowly and smoothly from the level and hard soil ground.

FJ OPERATING CONDITION LOAD CHART

SCC8300 10° between boom and jib and 42m fixed jib load chart

Boom No.2825A/Fixed jib No.2316A 128t + 57t 360°

Unit: (t)

Radius (m)	20	26	32	38	44	50	56	62	68	Radius (m)
18	16.2	16.3	16.1	15.9	-	-	-	-	-	18
20	15.0	15.0	15.1	15.3	15.1	14.9	14.8	-	-	20
22	13.9	13.9	14.2	14.8	14.2	14.0	14.0	13.6	13.2	22
24	12.8	12.9	13.3	14.0	13.3	13.2	13.2	13.0	12.6	24
26	11.8	12.2	12.6	13.1	12.7	12.6	12.6	12.5	12.2	26
28	11.0	11.6	12.0	12.2	11.9	11.8	12.0	12.0	12.0	28
30	10.5	11.2	11.6	11.7	11.4	11.4	11.6	11.7	11.6	30
32	10.1	10.7	11.0	11.0	10.8	10.9	11.1	11.3	11.3	32
34	9.6	10.2	10.4	10.3	10.3	10.5	10.7	10.9	11.0	34
36	8.9	9.5	9.8	9.8	9.8	10.0	10.2	10.5	10.7	36
38	8.4	8.9	9.2	9.2	9.3	9.6	9.8	10.1	10.4	38
40	7.7	8.1	8.5	8.7	8.8	9.0	9.3	9.7	10.0	40
44	6.4	7.5	8.0	8.1	8.4	8.6	8.8	9.3	9.7	44
48	5.3	6.7	7.4	7.5	7.8	8.1	8.3	8.8	9.3	48
52	4.3	6.0	6.8	7.0	7.4	7.7	7.9	8.4	8.9	52
56	-	5.6	6.2	6.4	6.8	7.1	7.4	8.0	8.5	56
60	-	-	5.7	6.0	6.2	6.5	7.0	7.7	8.2	60
64	-	-	5.4	5.7	5.7	6.0	6.6	7.4	7.8	64
68	-	-	-	5.4	5.3	5.5	6.2	6.9	7.2	68
72	-	-	-	-	4.9	5.2	6.0	6.3	6.5	72
76	-	-	-	-	-	5.0	5.8	5.9	5.9	76
80	-	-	-	-	-	-	5.5	5.3	5.3	80
84	-	-	-	-	-	-	-	4.8	4.8	84
88	-	-	-	-	-	-	-	-	4.4	88
Lines	2	2	2	2	2	1	1	1	1	Lines

※ Note

1. The actual weight is a value that the rated weight in this chart is subtracted by the weights of the hooks, hangers, and wire ropes winding on the hooks and on the boom head.
2. The rated load in chart refers to a value under the condition that the heavy load is lifted slowly and smoothly from the level and hard soil ground.

※ Note Generally, there are 10°, 20° and 30° for the angle between fixed jib and boom.

FJh OPERATING CONDITIONS

Jib length	Jib insert (m)	Boom length and angle between boom and jib
12	-	20~74m 10°
18	1	15° 20°

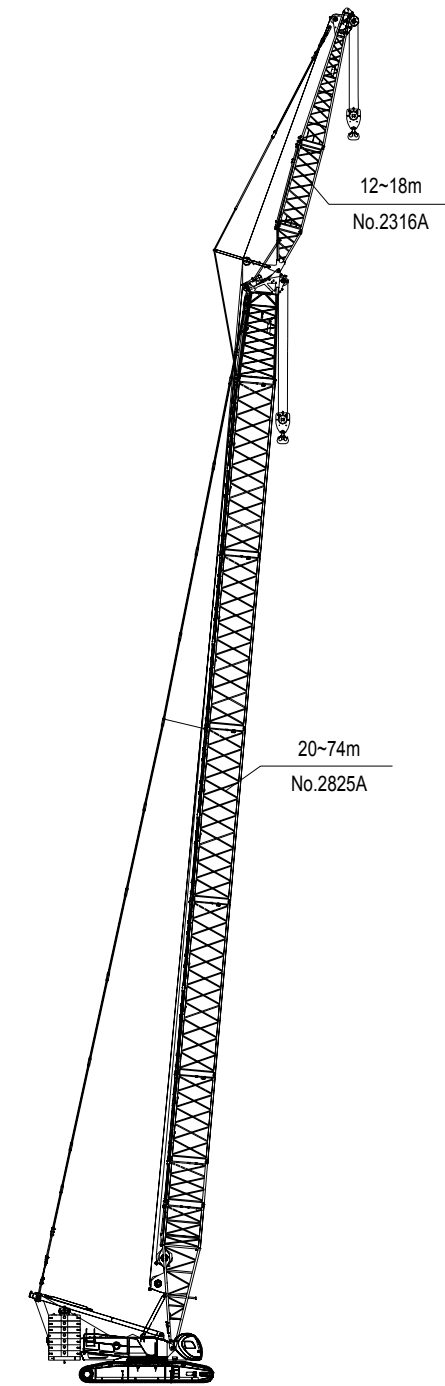

FJh Operating condition
Longest combination: 92m

F_h OPERATING CONDITION RANGE DIAGRAM

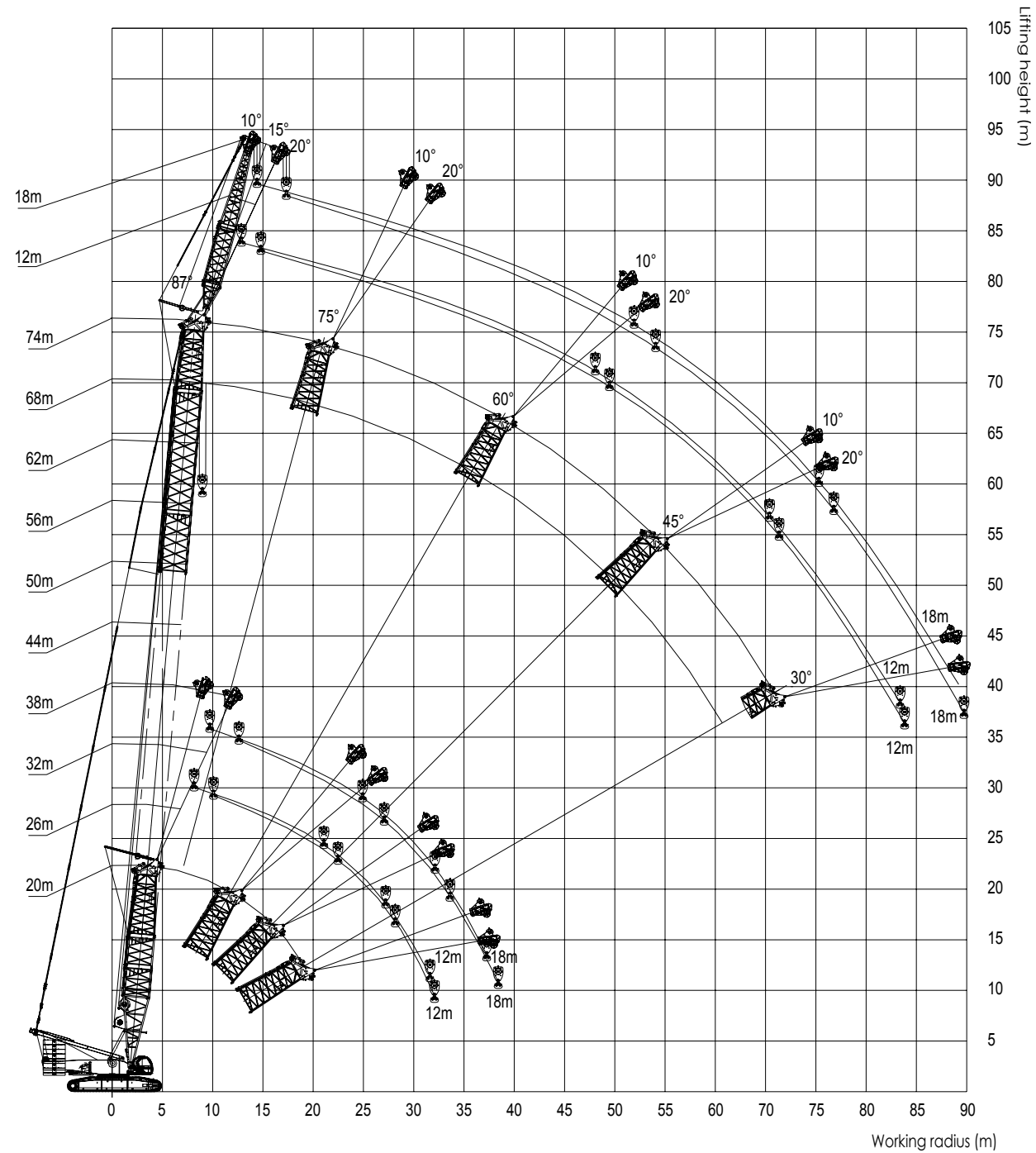

F_h OPERATING CONDITION LOAD CHART

SCC8300 10° between boom and jib and 12m heavy jib load chart

Boom No.2825A/Heavy jib/No.2316A 128t + 57t 360°

Unit: (t)

Radius (m)	20	26	32	38	44	50	56	62	68	74	Radius (m)
8	88.4	99.3	99.4	98.8	-	-	-	-	-	-	8
10	77.8	90.4	95.9	100.1	99.4	99.8	99.7	89.2	70.9	49.1	10
12	69.5	76.9	82.5	87.4	91.4	95.3	98.2	87.5	69.6	49.6	12
14	60.8	67.1	72.8	77.3	81.6	85.5	88.8	85.7	68.2	48.1	14
16	53.5	59.7	65.0	69.7	73.7	77.7	81.2	84.0	66.7	47.5	16
18	47.8	53.5	58.6	63.3	67.4	71.1	74.7	74.0	65.1	47.1	18
20	43.3	48.7	53.5	58.0	62.1	65.8	68.0	65.8	63.6	46.8	20
22	39.5	44.7	49.3	53.5	57.5	61.2	60.9	58.9	57.0	46.3	22
24	36.3	41.2	45.7	49.8	53.7	56.8	55.0	53.1	51.4	45.9	24
26	33.7	38.4	42.6	46.6	50.2	51.5	49.9	48.1	46.5	45.5	26
28	31.4	35.8	39.9	43.8	47.3	47.0	45.4	43.8	42.3	41.5	28
30	-	33.7	37.5	41.2	43.8	43.0	41.6	40.1	38.6	37.9	30
32	-	31.8	35.5	39.0	39.9	39.3	38.2	36.7	35.4	34.8	32
34	-	30.1	33.7	36.9	36.4	35.9	35.1	33.8	32.5	31.9	34
36	-	-	32.1	33.8	33.4	32.9	32.4	31.1	29.9	29.4	36
38	-	-	30.6	31.2	30.7	30.2	29.7	28.7	27.5	27.1	38
40	-	-	-	28.8	28.4	27.8	27.3	26.6	25.4	25.1	40
42	-	-	-	26.6	26.2	25.7	25.2	24.6	23.5	23.2	42
44	-	-	-	-	24.3	23.7	23.2	22.6	21.7	21.5	44
46	-	-	-	-	22.5	22.0	21.5	20.9	20.1	19.9	46
48	-	-	-	-	-	20.4	19.8	19.3	18.6	18.4	48
50	-	-	-	-	-	18.9	18.4	17.8	17.2	17.1	50
52	-	-	-	-	-	17.5	17.0	16.4	15.9	15.8	52
54	-	-	-	-	-	-	15.8	15.2	14.6	14.7	54
56	-	-	-	-	-	-	14.6	14.0	13.5	13.6	56
58	-	-	-	-	-	-	-	12.9	12.4	12.6	58
60	-	-	-	-	-	-	-	11.9	11.4	11.6	60
62	-	-	-	-	-	-	-	-	10.4	10.7	62
64	-	-	-	-	-	-	-	-	9.6	9.9	64
66	-	-	-	-	-	-	-	-	8.7	9.1	66
68	-	-	-	-	-	-	-	-	-	8.3	68
70	-	-	-	-	-	-	-	-	-	7.6	70
Lines	6	7	7	7	7	7	7	6	5	4	Lines

※ Note

1. The actual weight is a value that the rated weight in this chart is subtracted by the weights of the hooks, hangers, and wire ropes winding on the hooks and on the boom head.
2. The rated load in chart refers to a value under the condition that the heavy load is lifted slowly and smoothly from the level and hard soil ground.

F_h OPERATING CONDITION LOAD CHART

SCC8300 10° between boom and jib and 18m heavy jib load chart

Boom No.2825A/Heavy jib/No.2316A 128t + 57t v 360°

Unit: (t)

Radius (m)	20	26	32	38	44	50	56	62	68	74	Radius (m)
10	63.3	69.4	72.3	74.3	76.4	78.2	-	-	-	-	10
12	55.5	59.2	62.3	65.1	67.2	69.4	71.3	71.6	57.8	45.7	12
14	47.9	51.5	54.7	57.6	59.9	62.3	64.3	65.9	57.5	45.1	14
16	42.0	45.5	48.9	51.7	54.4	56.7	58.6	60.6	57.3	44.6	16
18	37.5	41.1	44.2	47.0	49.6	51.8	54.1	55.8	57.1	44.1	18
20	33.9	37.3	40.3	43.2	45.7	47.9	50.1	52.0	53.8	43.5	20
22	30.9	34.1	37.1	39.8	42.2	44.6	46.6	48.5	50.3	43.0	22
24	28.4	31.5	34.3	36.9	39.4	41.5	43.7	45.5	47.4	42.4	24
26	26.3	29.3	32.0	34.5	36.8	38.9	41.1	43.0	44.7	41.9	26
28	24.5	27.4	29.9	32.4	34.6	36.7	38.7	40.6	42.3	41.4	28
30	22.9	25.7	28.2	30.5	32.7	34.7	36.7	38.4	38.7	37.9	30
32	21.6	24.2	26.6	28.8	31.0	33.0	34.8	36.6	35.5	34.8	32
34	20.4	22.9	25.2	27.4	29.4	31.4	33.2	34.0	32.7	32.0	34
36	-	21.7	23.9	26.0	28.0	29.9	31.7	31.3	30.1	29.6	36
38	-	20.7	22.8	24.8	26.8	28.6	30.2	29.0	27.8	27.3	38
40	-	-	21.8	23.8	25.6	27.4	28.0	26.8	25.7	25.3	40
42	-	-	20.9	22.8	24.5	26.3	25.8	24.9	23.8	23.4	42
44	-	-	-	21.9	23.6	24.4	23.9	23.1	22.0	21.7	44
46	-	-	-	21.0	22.7	22.7	22.1	21.5	20.4	20.1	46
48	-	-	-	20.3	21.6	21.0	20.5	19.9	18.9	18.7	48
50	-	-	-	-	20.1	19.6	19.0	18.4	17.6	17.3	50
52	-	-	-	-	18.8	18.2	17.7	17.1	16.3	16.1	52
54	-	-	-	-	-	16.9	16.4	15.8	15.1	14.9	54
56	-	-	-	-	-	15.8	15.2	14.6	14.0	13.9	56
58	-	-	-	-	-	-	14.2	13.6	13.0	12.8	58
60	-	-	-	-	-	-	13.1	12.5	12.0	11.9	60
62	-	-	-	-	-	-	12.2	11.6	11.0	11.0	62
64	-	-	-	-	-	-	-	10.7	10.1	10.2	64
66	-	-	-	-	-	-	-	9.9	9.3	9.4	66
68	-	-	-	-	-	-	-	-	8.5	8.6	68
70	-	-	-	-	-	-	-	-	7.8	7.9	70
72	-	-	-	-	-	-	-	-	-	7.2	72
74	-	-	-	-	-	-	-	-	-	6.6	74
Lines	5	5	5	5	6	6	5	5	4	4	Lines

※ Note

- The actual weight is a value that the rated weight in this chart is subtracted by the weights of the hooks, hangers, and wire ropes winding on the hooks and on the boom head.
- The rated load in chart refers to a value under the condition that the heavy load is lifted slowly and smoothly from the level and hard soil ground.

※ Note there are 10°, 15° and 20° for the angle between heavy fixed jib and boom.

HJFJ OPERATING CONDITIONS

Jib length (m)	Jib insert		Boom length and angle between boom and jib
	3m	6m	
13	1	-	64~82m 10° 20° 30°
19	1	1	
25	1	2	
31	1	3	
37	1	4	

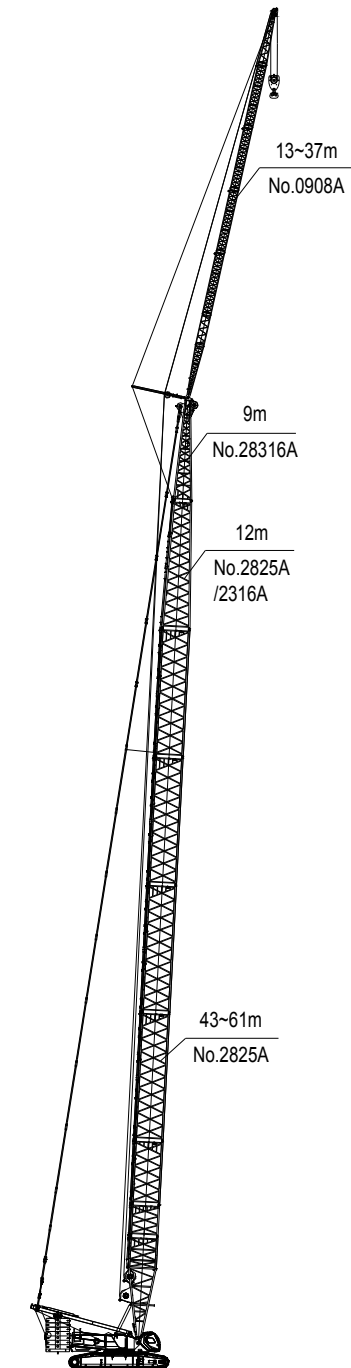

HJFJ Operating condition
Longest combination: 119m



Quality Changes the World

SANY HEAVY INDUSTRY CO., LTD.

Address: SANY Industrial Park, Economic and Technological
Development Zone, Changsha, Hunan, China

Service Hotline: +0086-4006-098-318

E-mail: crd@sany.com.cn

For more information, please visit: www.sanygroup.com

